



ACCESS TRUCK PARTS



SOLUTIONS CATALOG

8TH EDITION

QUALITY PARTS & SOLUTIONS

Access Truck Parts is "Your One Stop Water Truck Parts Solution". Our comprehensive inventory features replacement parts for all brands and manufacturers of water trucks, water towers, and mine tankers. No matter what industry you're in or brand of equipment you use, we stock the replacement parts you need to stay up and running.

With over 30 years of industry experience, we offer in-depth knowledge of water pumps, control valves, spray heads, hose reels, or any other water truck parts you may encounter. Our extensive international vendor network and manufacturing capabilities allow us to provide these high quality parts at the best available pricing the market has to offer.

We hope you find this catalog a valuable resource and reference tool to help you find the parts you need to keep your water trucks and other equipment in optimum working condition. Just like our website, this catalog is divided into categories to help you find replacement parts quickly.

See the Table of Contents on the following page or simply browse through the catalog to see the diversity of parts we offer. You may find additional products that would enhance the performance of your equipment.

WAYS TO ORDER YOUR PARTS:

Online: acesstruckparts.ca

Email: sales@acesstruckparts.ca

Phone: 877-583-5275



Find us online!

The logo for Access Truck Parts, featuring the company name in a bold, italicized, blue and black font with a white outline. The logo is positioned at the bottom center of the page, above a decorative water splash graphic.

ACCESS TRUCK PARTS

WATER PUMPS.....	3	Groove Nipples	25
B3Z Rope Seal Pump.....	3	Groove Reducers.....	25
B3Z Mechanical Seal Pump.....	4	Other Nipples.....	25
B3Z Heavy Duty Rope Seal Pump.....	5	Elbows	26
B3Z Hydraulic Frame Pump.....	6	Couplings / Reducers	26
B3Z SAE B Hydraulic Frame Pump.....	7	Tees	26
B3ZQ-S SAE 5 Mechanical Seal Engine Mount Pump.....	8	CAMLOCKS.....	27
B4Z Self-Priming Pump	9	RAASM LUBE & FUEL.....	28
B3J Mechanical Seal High Pressure Pump.....	10	WATER CANNONS & TANK HARDWARE.....	29
B4J 5 x 4 Mechanical Seal Pump (Splined).....	11	The Tempest 12V/24V Water Cannon.....	29
B4J 5 x 4 Rope Seal Pump (Keyed)	12	Tempest Cannon Parts Diagram	30
B6Z High Volume Pump.....	13	Tempest Cannon Parts	31
Stainless Steel 4 x 3 Mechanical Seal Pump (Potable)	14	Tank Hardware.....	31
IN-LINE CONTROL VALVES	15	Hydraulics.....	31
Air Operated	15	Manual Cannons	32
Hydraulic.....	15	Cannon Nozzles.....	32
Manual Valves.....	15	Brush Hawk Electric Water Cannon	32
FRONT & REAR SPRAY HEADS	16	Nitro Electric Water Cannon	32
Deflector Type Spray Heads	16	STANDARD PLUMBING LAYOUT	33
Air Operated Spray Head Valves.....	16	PLUMBING INFORMATION	34
Hydraulic.....	16	CAB CONTROLS	35
SIDE SPRAY HEADS.....	17	Air Control Panels.....	35
5" x ¼" Slot Fin Side Spray	17	Control Switches.....	35
7" Slot Duckbill Side Spray	17	Manual Controls & Cables	35
5" Slot Duckbill Side Spray	17	AIR & OTHER FITTINGS	36
90° Side Spray.....	18	Air Hose Fittings	36
Side Spray Head.....	18	Quick Exhaust Valves	36
Street Flusher	18	Air Cylinders	36
SPRAY HEAD KITS	19	Misc Fittings	36
Diaphragm Valve Assemblies	19	HOSES & NOZZLES.....	37
Threaded CLA Style Valve Assemblies.....	19	Hose.....	37
Tee Valve Assemblies	20	Nozzles.....	37
Grooved Spray Head Assembly	20	Hose Clamps	37
VALVE REBUILD KITS	21	Hand Primers	37
3" Grooved Spray Head Valve Rebuild Kit	21	Strainer / Foot Valve	37
3" Heavy Duty Spray Head Valve Rebuild Kit.....	21	Hydrant Tools	37
3" Grooved Tee Valve Rebuild Kit.....	21	HOSE REELS.....	38
Threaded CLA Style Valve Rebuild Kit.....	22	Hose Reel Kits.....	38
3" Grooved Normally Closed Inline Valve Rebuild Kit.....	22	Electric Rewind Reels	38
3" Dome Diaphragm Valve Rebuild Kit	22	ATP Leak Free NPT Swivel Hose Reel.....	38
3" Threaded Vawew Style Spray Head Rebuild Kit.....	22	Hose Reel Parts	38
AGM Style Valve Rebuild Kit.....	22	GENERAL PUMP INFORMATION.....	39
F/E Valve Rebuild Kit.....	22	PUMP MAINTENANCE SCHEDULE	40
GROOVE COUPLINGS	23	PUMP PERFORMANCE CURVES	41
Coupling Variations	23	ATP Notes.....	43
FITTINGS.....	24	POWERX INTERNATIONAL.....	45
Groove Elbows.....	24	SUMMIT HYDRAULICS.....	46
Swivels	24		
Groove Tees, Cross & Caps.....	24		

NEED PUMP SELECTION HELP? SEE PAGE 39

B3Z ROPE SEAL PUMP

COMPLETE WATER PUMP

Grooved, Rope Seal

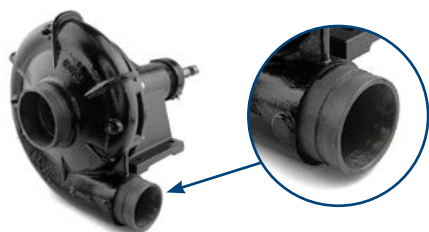

107-B66899 Shown Here

TYPE	SKU
CW B3Z Grooved Pump	107-B66899
CCW B3Z Grooved Pump	107-B66895

COMPLETE WATER PUMP

Threaded, Rope Seal

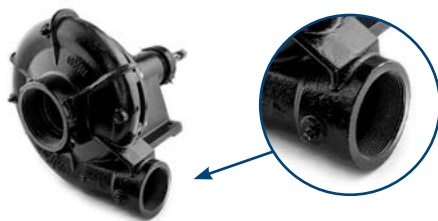

104-B66161 Shown Here

TYPE	SKU
CW B3Z Threaded Pump	104-B66161
CCW B3Z Threaded Pump	104-B66168

ROPE SEAL POWER FRAME

Everything but the Volute



103-B85552 Shown Here

TYPE	SKU
CW B3Z Power Frame	103-B85552
CCW B3Z Power Frame	103-B85551

IMPELLER

Cast Iron, Threaded



Clockwise (CW) Counterclockwise (CCW)

TYPE	SKU
CW B3Z Impeller	112-M02153
CCW B3Z Impeller	112-M02181

KEYED SHAFT KIT

Shaft, Bearings, Sleeve, Locknut & Keyway



TYPE	SKU
CW B3Z Shaft Kit	111-B80698
CCW B3Z Shaft Kit	111-B80696

COMPLETE REBUILD KIT

All Internal Replacement Parts



TYPE	SKU
CW B3Z Rope Seal Rebuild Kit	1011-RP0
CCW B3Z Rope Seal Rebuild Kit	1011-RP1

ALL COMPONENTS

PART NAME	SKU
1 Volute Case, Grooved, CW	113-H04040
1 Volute Case, Grooved, CCW	113-H04041
1 Volute Case, Thread, CW	113-H00689
1 Volute Case, Thread, CCW	113-H00698
2 Impeller, CW	112-M02153
2 Impeller, CCW	112-M02181
3 Volute Gasket	116-S05126
3a Volute O-Ring	116-M14943
(* Pump accepts either O-Ring or Gasket)	
4 Pump Frame, Rope Seal	114-H00553
5 Outer Bearing Cap	116-S19914
*6 1/8" Key Way	116-S24255
*7 Shaft Kit, CW	111-B80698
*7 Shaft Kit, CCW	111-B80696
8 Inner Bearing Cap	116-S19033
9 Water Slinger	116-S12260
10 Split Packing Gland	116-B82468
11 Nut, 3/8"-16 (2 Req)	116-S23343
12 Bolt, Sq Head 3/8"-16 x 2 1/2"	116-S23762
13 Rope Packing (Set of 6)	116-S14022
*14 Impeller Lock Nut (CCW)	116-U36189
*14 Impeller Lock Nut (CW)	116-M10220
*15 Shaft Sleeve (For Rope & Mech)	116-S39242
*16 Ball Bearing	116-S13270
*17 Ball Bearing	116-S13271
*18 Thrust Ring	116-S29218
*19 Retaining Snap Ring	116-S23010
*20 Capscrew (B3Z) 3/8-16 by 1" (6 Required)	116-S26826
*21 Capscrew (B4Z) 3/8-16 x 1-1/4" (2 Required)	116-S26828

* Items included in shaft kit

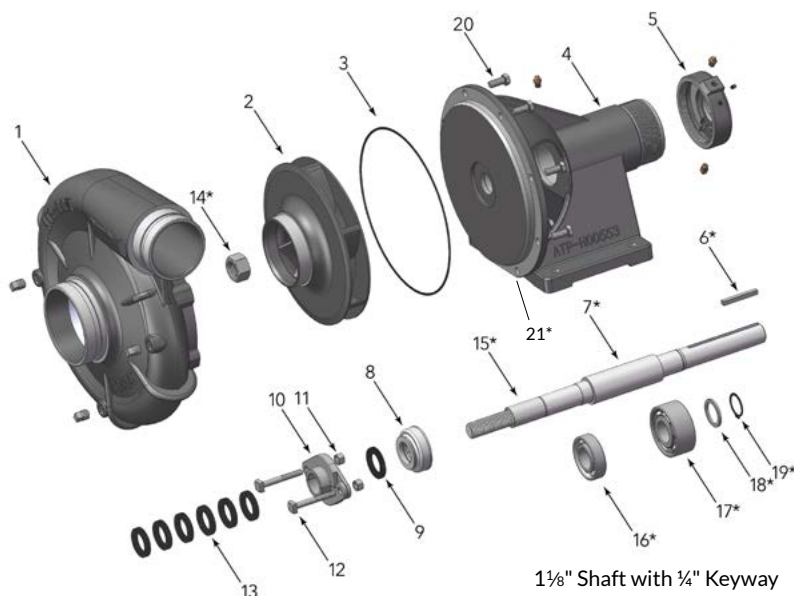

Scan Here for Pump Selector!

B3Z MECHANICAL SEAL PUMP

COMPLETE WATER PUMP Grooved, Mechanical Seal

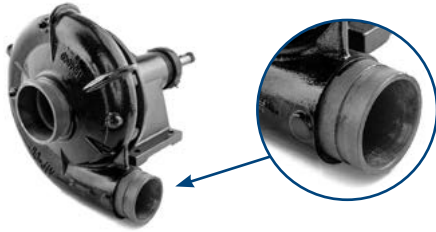

107-B68417 Shown Here

TYPE	SKU
CW B3Z Grooved Pump	107-B68417
CCW B3Z Grooved Pump	107-B68416

COMPLETE WATER PUMP Threaded, Mechanical Seal

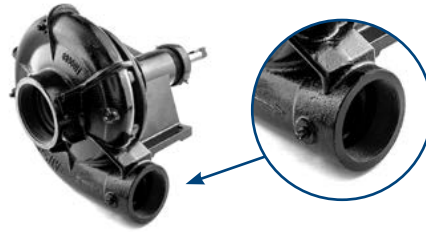

108-B68414 Shown Here

TYPE	SKU
CW B3Z Threaded Pump	108-B68414
CCW B3Z Threaded Pump	108-B68415

MECH SEAL POWER FRAME Everything but the Volute



103-B85550 Shown Here

TYPE	SKU
CW B3Z Power Frame	103-B85550
CCW B3Z Power Frame	103-B85549

IMPELLER Cast Iron, Threaded



Clockwise (CW) Counterclockwise (CCW)

TYPE	SKU
CW B3Z Impeller	112-M02153
CCW B3Z Impeller	112-M02181

KEYED SHAFT KIT Shaft, Bearings, Sleeve, Locknut & Keyway



TYPE	SKU
CW B3Z Shaft Kit	111-B80698
CCW B3Z Shaft Kit	111-B80696

COMPLETE REBUILD KIT All Internal Replacement Parts



TYPE	SKU
CW B3Z Mech Seal Rebuild Kit	1011-MS0
CCW B3Z Mech Seal Rebuild Kit	1011-MS1

ALL COMPONENTS

PART NAME	SKU
1 Volute Case, Grooved, CW	113-H04040
Volute Case, Grooved, CCW	113-H04041
Volute Case, Thread, CW	113-H00689
Volute Case, Thread, CCW	113-H00698
2 Impeller, CW	112-M02153
Impeller, CCW	112-M02181
3 Volute Gasket	116-S05126
3a Volute O-Ring	116-M14943
(*Pump accept either O-Ring or Gasket)	
4 Pump Frame, Mechanical Seal	114-H04007
5 Outer Bearing Cap	116-S19914
*6 1/4" Key Way	116-S24255
*7 Shaft Kit, CW	111-B80698
*7 Shaft Kit, CCW	111-B80696
8 Inner Bearing Cap	116-S19033
9 Water Slinger	116-S12260
10 Mechanical Seal	116-S32690
*12 Retaining Ring	116-S23009
*14 Impeller Lock Nut (CCW)	116-U36189
*14 Impeller Lock Nut (CW)	116-M10220
*15 Shaft Sleeve (For Rope & Mech)	116-S39242
*16 Ball Bearing	116-S13270
*17 Ball Bearing	116-S13271
*18 Thrust Ring	116-S29218
*19 Retaining Snap Ring	116-S23010

* Items included in shaft kit

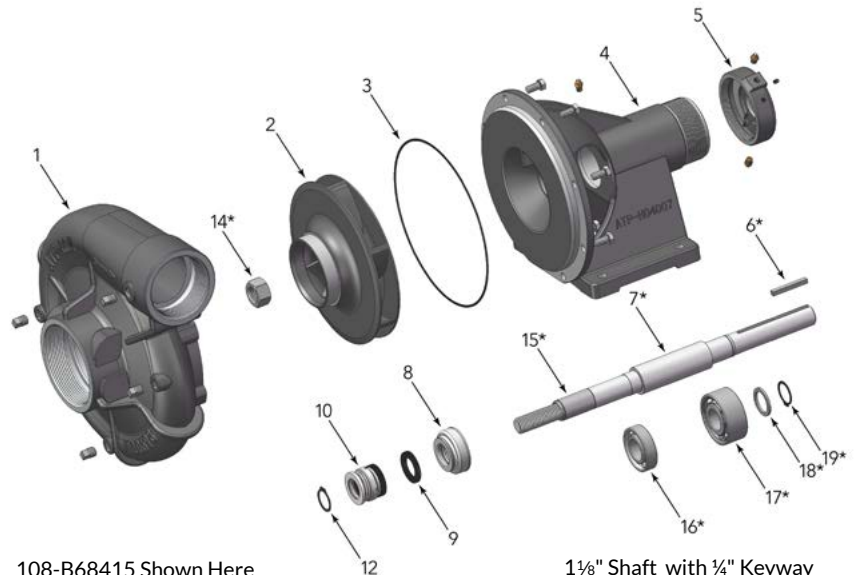

108-B68415 Shown Here

1 1/8" Shaft with 1/4" Keyway

WATER PUMPS

B3Z HEAVY DUTY ROPE SEAL PUMP

COMPLETE WATER PUMP CW, Threaded, Rope Seal



TYPE	SKU
CW B3Z-HD Threaded Pump	101-B86070

COMPLETE WATER PUMP CCW, Threaded, Rope Seal



TYPE	SKU
CCW B3Z-HD Threaded Pump	101-B85874

HD ROPE SEAL POWER FRAME Everything but the Volute



103-B86070 Shown Here

TYPE	SKU
CW B3Z-HD Power Frame	103-B86070
CCW B3Z-HD Power Frame	103-B85874

IMPELLER Cast Iron, Keyed



Clockwise (CW) Counterclockwise (CCW)

TYPE	SKU
CW B3Z-HD Impeller	112-M14994
CCW B3Z-HD Impeller	112-M14989

HD KEYED SHAFT KIT Shaft, Bearings, Sleeve, Locknut & Keyway



TYPE	SKU
CW B3Z-HD Shaft Kit	111-B85585
CCW B3Z-HD Shaft Kit	111-B85916

COMPLETE REBUILD KIT All Internal Replacement Parts



TYPE	SKU
CW B3Z-HD Rope Seal Rebuild Kit	1011-RPHD0
CCW B3Z-HD Rope Seal Rebuild Kit	1011-RPHD1

ALL COMPONENTS

PART NAME	SKU
1 Volute Case, Thread, CW	113-H00689
Volute Case, Thread, CCW	113-H00698
2 Keyed Impeller, CW	112-M14994
Keyed Impeller, CCW	112-M14989
3 Volute Gasket	116-S05126
3a Volute O-Ring	116-M14943
(*Pump accept either O-Ring or Gasket)	
4 Pump Bearing Frame (Bracket)	114-M15690
5 Outer Bearing Cap	116-M14996
*6 Retaining Ring	116-S23025
*7 Shaft Kit, CW	111-B85585
*7 Shaft Kit, CCW	111-B85916
*8 Key, 3/8" x 3/8" x 1-3/8"	116-M15001
*9 Key, 1/4" x 1/4"	116-S23505
*10 Ball Bearing	116-M14999
*11 Ball Bearing	116-M14998
*12 Shaft Sleeve	116-M14993
*13 Impeller Lock Nut (CCW)	116-U36189
*13 Impeller Lock Nut (CW)	116-M10220
*14 Lock Washer	116-M14990
15 Rope Packing Ring (Set of 3)	116-S08291
16 Packing Ring, Metallic	116-S11092
17 Bolt, Sq Head 3/8"-16 x 2 1/2" (2 Req)	116-S23762
18 Nut, 3/8"-16 (2 Req)	116-S23343
19 Packing Gland, Split	116-B82470
20 Water Slinger	116-S10964
21 Inner Bearing Cap	116-M14997
22 Capscrew, Hex 3/8"-16 x 7/8"	116-S26825

* Items included in shaft kit

101-B85874 Shown Here

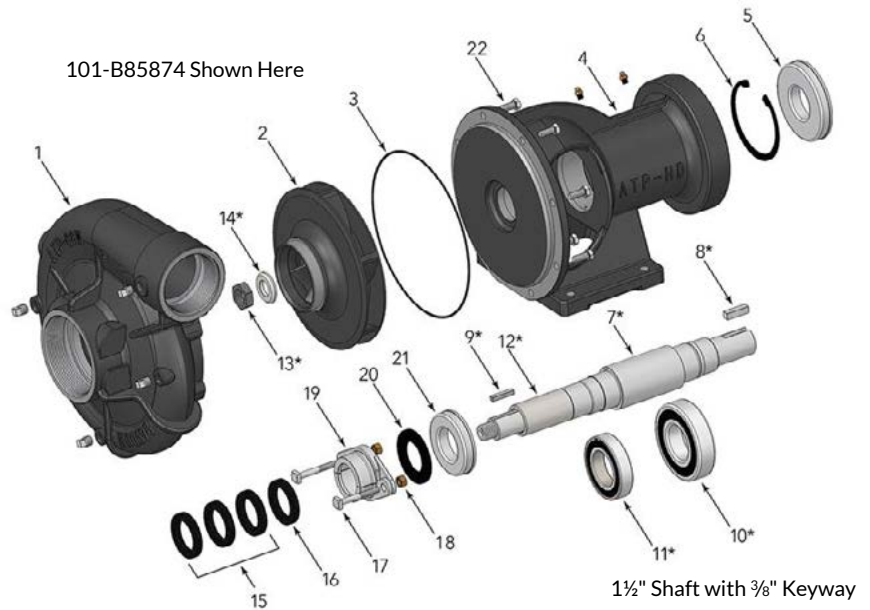

1 1/2" Shaft with 3/8" Keyway



Scan Here for Pump Selector!



NEED PUMP SELECTION HELP? SEE PAGE 39

B3Z HYDRAULIC FRAME PUMP

COMPLETE WATER PUMP

CW, Threaded, Hydraulic Frame



TYPE	SKU
CW B3Z Hydraulic Frame Pump	101-B69875

SPLINED SHAFT KIT

Shaft, Bearings, Sleeve & Locknut



TYPE	SKU
CW B3Z Splined Shaft Kit	111-B73052-3

IMPELLER

Cast Iron, Threaded



Clockwise (CW)

TYPE	SKU
CW B3Z Impeller	112-M02153

HYDRAULIC POWER FRAME

Everything but the Volute



TYPE	SKU
CW B3Z Hyd Power Frame	103-B69875



101-B69875 Pump shown here on an 8,000 Gallon, Volvo A40G Tank System
Manufactured by Tidal Wave Tanks, Mulberry Florida

ALL COMPONENTS

PART NAME	SKU
1 Volute Case, Thread, CW	113-H00689
† 2 Impeller, CW	112-M02153
3 Frame, Hydraulic Mount	114-H05119
† 4 Shaft Kit, CW SPLINED	111-B73053
* 5 Impeller Lock Nut (CW)	116-M10220
† 6 Volute Gasket	116-S05126
† * 7 Retaining Ring	116-S23023
† 8 Seal Retaining Ring	116-S23009
† 9 Mechanical Seal	116-S32690
† 10 Water Slinger	116-S12260
† 11 Inner Bearing Cap	116-S19033
* 12 Shaft Lock Nut	116-M10221
* 13 Lock Washer	116-S16181
* 14 Bearing, Ball	116-S13270
* 15 Seal, Oil	116-M10217
* 16 Outer Bearing Cap	116-M10214
* 17 Bearing, Ball	116-M10218
* 18 Washer, Thrust	116-M10222
* 19 Ring, Retaining	116-S23010
* 20 Shaft Sleeve	116-S39242
21 Capscrew, Hex 3/8-16 x 1"	116-S26826
† Pump Rebuild Kit	1011-MS3

* Items included in shaft kit

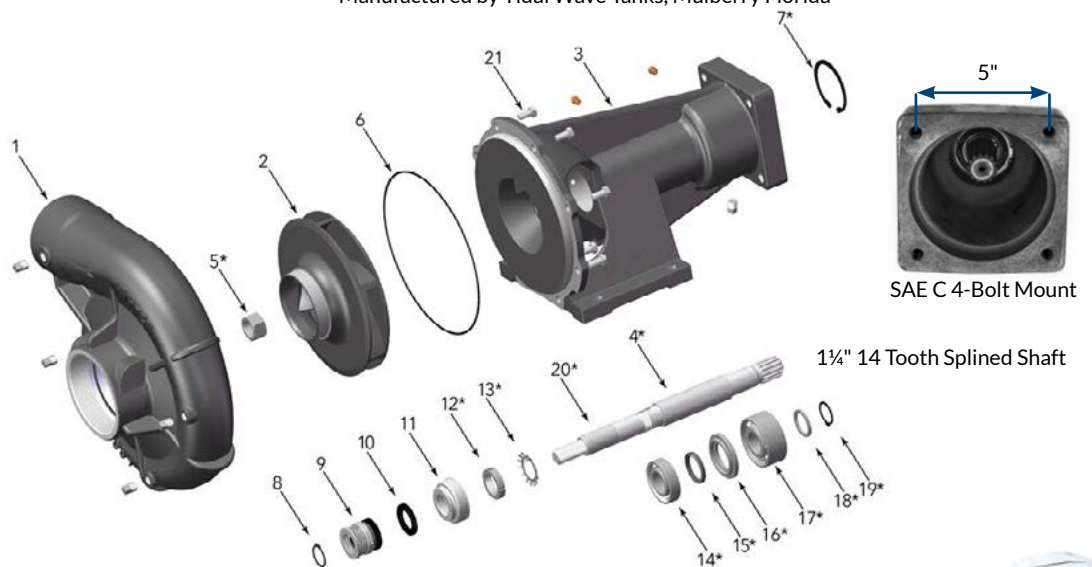

WATER PUMPS

NEED PUMP SELECTION HELP? SEE PAGE 39

B3Z SAE B HYDRAULIC FRAME PUMP

COMPLETE WATER PUMP

CW, Grooved, Rope Seal

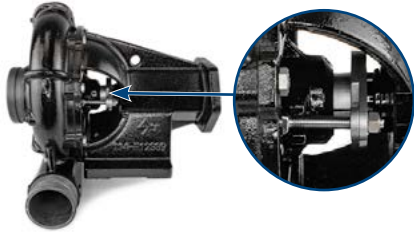

TYPE	SKU
CW B3Z SAE B Rope Seal Pump	101-B81203

COMPLETE WATER PUMP

CW, Grooved, Mech Seal

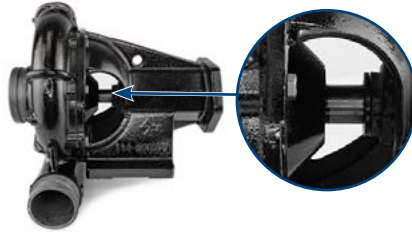

TYPE	SKU
CW B3Z SAE B Mech Seal Pump	101-B81223

SHAFT KIT

Shaft, Bearings & Lock Washer



7/8" - 13 Tooth

TYPE	SKU
CW B3Z SAE B Splined Shaft Kit	111-M80880

IMPELLER

Cast Iron, Threaded



Clockwise (CW)

TYPE	SKU
CW B3Z Impeller	112-M02153

ALL COMPONENTS (ROPE SEAL)

PART NAME	SKU
1 Volute, B3Z, CW, Groove	113-H04040
2 Impeller, B3Z, CW	112-M02153
3 Pump O-Ring, B3Z (Optional Volute Gasket)	116-M14943 116-S05126
4 SAE B Rope Seal Bearing Frame	114-H12389
5 Pump Retaining Ring	116-S23029
*6 Shaft Retaining Ring	116-S23010
*7 Shaft Thrust Ring	116-S29218
*8 Shaft Kit, Female Spline, 7/8"-13 Tooth	111-M80880
*9 Pump Bearing, Rear	116-S13271
*10 Pump Bearing, Front	116-S13270
*11 Pump Shaft Sleeve, B3Z	116-S05127
*12 Pump Lock Nut, B3Z, CW	116-M10220
13 Inner Bearing Cap	116-S19033
14 Pump Slinger	116-S12260
15 Gland Nut, B3Z	116-S23343
16 Pump Packing Gland Set	116-B82468
17 Gland Bolt, B3Z	116-S23762
18 Pump Rope Packing	116-S14022
19 Pipe Plug, 1/4", NPT	116-S23715
20 Capscrew, B3Z, 3/8-16x1", Hex	116-S26826

MECHANICAL SEAL COMPONENTS

PART NAME	SKU
4M SAE B Mech Seal Bearing Frame	114-M98321
22 Retaining Ring	116-S23009
23 Mechanical Seal	116-S32690

* Items included in shaft kit

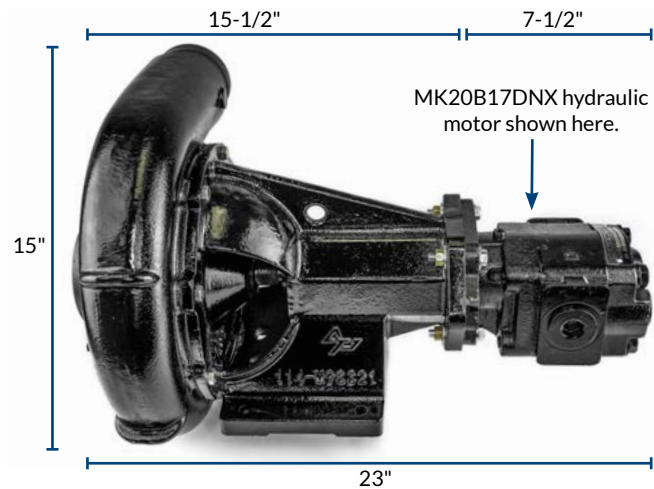

Hydraulic motor size should be specified based on existing hydraulic system.

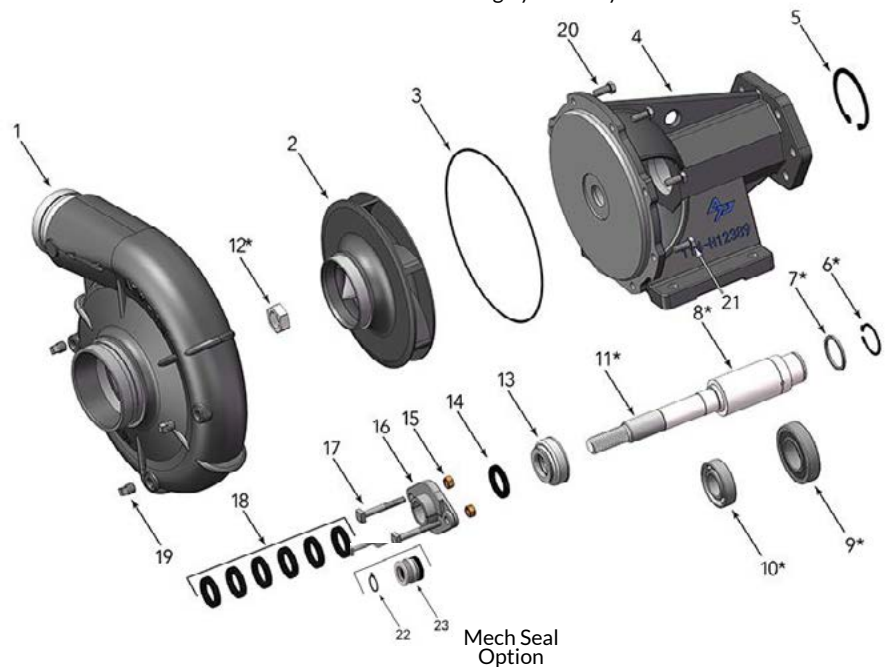

7/8" 13 Tooth Female Splined Shaft



Scan Here for Pump Selector!

ACCESS TRUCK PARTS

B3ZQ-S SAE 5 MECHANICAL SEAL ENGINE MOUNT PUMP

COMPLETE WATER PUMP

CW, Grooved, Mech Seal



TYPE	SKU
CW B3ZQ-S Grooved Pump	101-B69963

IMPELLER

Cast Iron, Threaded



Clockwise (CW)

TYPE	SKU
CW B3ZQ-S Impeller	112-M04275

SHAFT KIT

Shaft, Bearings, Lock Washer & Bolt



TYPE	SKU
CW B3ZQ-S Splined Shaft Kit	111-B71878

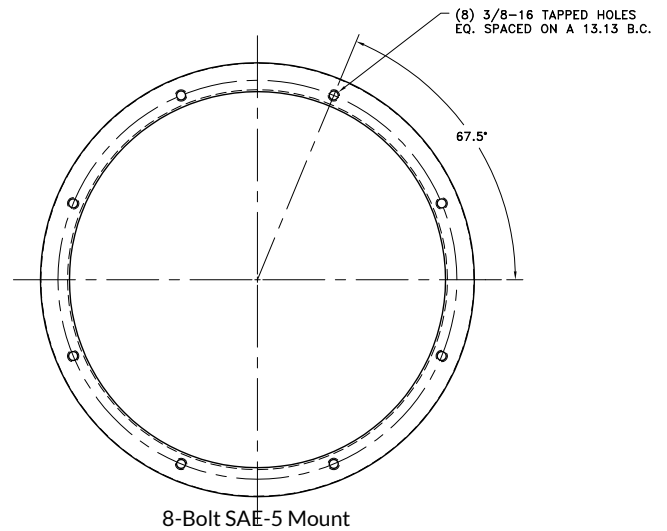

ALL COMPONENTS

PART NAME	SKU
1 Volute, CW, Grooved	113-H04040
2 Impeller, CW	112-M04275
3 SAE Pump Bracket	114-H04003
*4 Shaft Kit	111-B71878
5 O-Ring, Volute (Optional Volute Gasket)	116-M14943 116-S05126
6 Seal Retainer	116-M06063
7 Gasket, Seal Retainer	116-S16800
8 Ring, Retaining	116-S24652
*9 Bearing, Ball	116-S14059
*10 Ring, Retaining (2 Req)	116-S23010
*11 Bearing, Ball	116-S13270
12 Seal, Mechanical Shaft	116-S32690
*13 Ring, Snap	116-S23009
14 Seal, Oil	116-S14762
15 Water Slinger	116-S12260
*16 Washer, Impeller	116-S06314
*17 Washer, Lock	116-S23036
*18 Screw, Impeller, 3/8-16 x 1"	116-S23566
*19 Sleeve, Shaft	116-S39242
20 Capscrew, Hex 3/8-16 x 7/8" (8 Req)	116-S26825
21 Stud, 3/8-16 x 1-1/4" (4 Req)	116-S23944
22 Nut, Hex 3/8-16 (4 Req)	116-S23103

* Items included in shaft kit

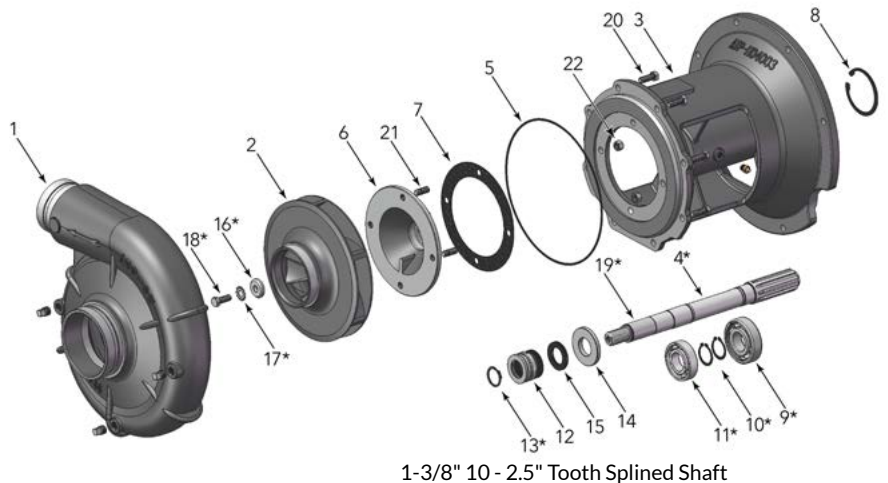

1-3/8" 10 - 2.5" Tooth Splined Shaft

B4Z SELF-PRIMING PUMP

COMPLETE WATER PUMP

CW, Threaded, Mech Seal



Uses 111-B80698 Keyed Shaft

TYPE	SKU
CW B4Z Pump	102-B69880

COMPLETE WATER PUMP

CW, Threaded, Mech Seal, Hyd Adaptor



Comes with 115-B07779 Hydraulic Adaptor

TYPE	SKU
CW B4Z Hyd Mount Pump	102-B69876

B4Z MECH SEAL POWER FRAME

Everything but the Volute



Comes with 115-B07779 Hydraulic Adaptor

TYPE	SKU
CW B4Z Power Frame	102-B69876P

SHAFT KIT

Shaft, Bearings, Sleeve, Locknut & Keyway



111-B80703 Shown Here

TYPE	SKU
CW B4Z Shaft Kit	111-B80698
CW B4Z Hyd Mount Shaft Kit	111-B80703

HYDRAULIC ADAPTOR KIT

Replaces Outer Bearing Cap



Used with 111-B80703 Shaft Kit

TYPE	SKU
B3Z/B4Z Hydraulic Adaptor	115-B07779

IMPELLER

Cast Iron, Threaded



Clockwise (CW)

TYPE	SKU
CW B4Z Impeller	112-M08095

ALL COMPONENTS

PART NAME	SKU
1 Volute, Self Priming	113-H02505
2 Impeller, CW	112-M08095
3 Pump Frame, Mechanical Seal	114-H04007
*4 Shaft Kit, Keyed	111-B80703
*5 Impeller Lock Nut (CW)	116-M10220
6 Volute Gasket	116-S05126
*7 External Retaining Ring	116-S23009
8 Mechanical Seal	116-S32690
9 Water Slinger	116-S12260
10 Inner Bearing Cap	116-S19033
*11 Shaft Sleeve (For Rope & Mech)	116-S39242
*12 Ball Bearing	116-S13270
*13 Ball Bearing	116-S13271
*14 Shaft Thrust Ring	116-S29218
*15 Retaining Ring	116-S23010
16 Hydraulic Adaptor Kit (with 116-S30636)	115-B07779
17 Shaft Coupling (7/8" Splined)	116-S30636
#18 Capscrew, Hex 3/8-16 x 3/4"	116-S26824
#19 Clack Weight	116-S14842
#20 Clack Gasket	116-L04119
#21 Clack Weight	116-S15325
#22 Pump Nut, Hex 3/8-16	116-S23103
23 Capscrew, Hex 3/8-16 x 1" (8 Req)	116-S26826
24 Pump Companion Flange	116-S15933
25 Pump Flange Gasket	116-S10364
26 Capscrew, Hex 5/8-11 x 3/4" (4 Req)	116-S27001
27 Pump Cover	116-L04108
28 Capscrew, Hex 3/8-16 x 1-1/4" (8 Req)	116-S26828
# Complete Clack Assembly	116-L91140

* Items included in shaft kit

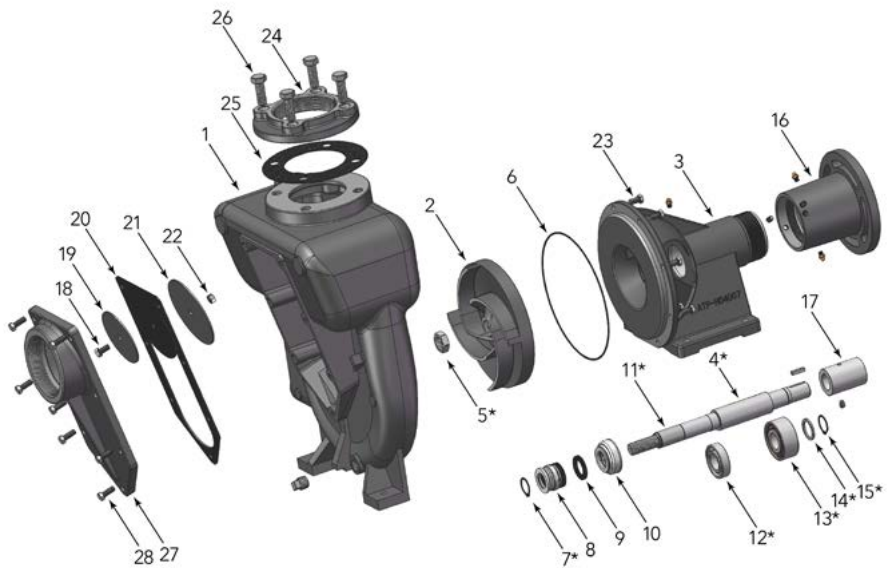

102-B69876 Shown Here

1-1/8" Shaft with 1/4" Keyway



Scan Here for Pump Selector!

NEED PUMP SELECTION HELP? SEE PAGE 39

B3J MECHANICAL SEAL HIGH PRESSURE PUMP

COMPLETE WATER PUMP

CW, Grooved, Mech Seal



5" Groove

TYPE	SKU
CW B3J Grooved Pump	101-B73403GR

COMPLETE WATER PUMP

CW, Threaded, Mech Seal

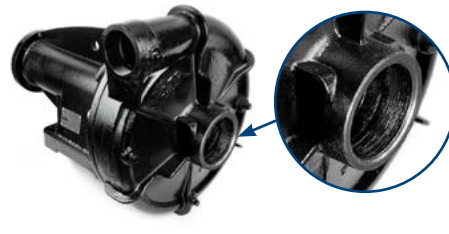

TYPE	SKU
CW B3J Threaded Pump	101-B73403

IMPELLER

Cast Iron, Threaded



Clockwise (CW)

TYPE	SKU
CW B3J Impeller	112-L03038

SHAFT KIT

Shaft, Bearings, Lock Washer & Bolt



TYPE	SKU
CW B3J Splined Shaft Kit	111-B73051

ALL COMPONENTS

	PART NAME	SKU
1	Volute Case, CW, Threaded	113-H01863
1	Volute Case, CW, Grooved	113-H01863GR
† 2	CW Impeller, 13-1/2" Diameter	112-L03038
3	Pump Bearing Frame	114-M05103
† * 4	Shaft Kit (Hydraulically Driven)	111-B73051
† 5	Ring, Wearing	116-S04176
* 6	Screw, Impeller 1/2-13 x 1-1/2"	116-S23623
* 7	Lock Washer	116-S23038
* 8	Washer, Impeller	116-S19275
9	Ring, Balance	116-M05073
10	Gasket, Balance Ring	116-S09943
† 11	Gasket, Volute	116-S06271
† 12	Seal, Mechanical Shaft	116-S32693
† 13	O-Ring	116-S26471
† 14	Bolt, Sq. Head 1/2-13 x 2-1/4" (2 Req)	116-S23792
† 15	Retainer, Mechanical Shaft Seal	116-S11452
† 16	Nut, Hex 1/2-13 x 7/16" (2 Req)	116-S23347
† 17	Slinger, Water	116-S10964
† 18	Inner Bearing Cap	116-M10200
† 19	Seal, Oil	116-S14765
* 20	Bearing, Ball	116-S15604
† * 21	Seal, Oil	116-M10210
† * 22	Outer Bearing Cap	116-M10209
* 23	Bearing, Ball	116-M10184
* 24	Ring, Thrust	116-S06519
* 25	Ring, Retaining	116-S23016
26	Plug, Pipe 1/2" NPT (4 Req.)	116-S23717
27	Plug, Pipe 1/4" NPT	116-S23715
28	Fitting, Grease (2 Req.)	116-S23670
29	Capscrew, Hex 5/8-11 x 1-1/2 (12 Req)	116-S26999
† * 30	Ring, Retaining	116-S23025
†	Pump Rebuild Kit	1011-B3JS

* Items included in shaft kit



101-B73403GR shown here on Coleman's Equipment 8,000 Gallon CAT 745 Tank System.

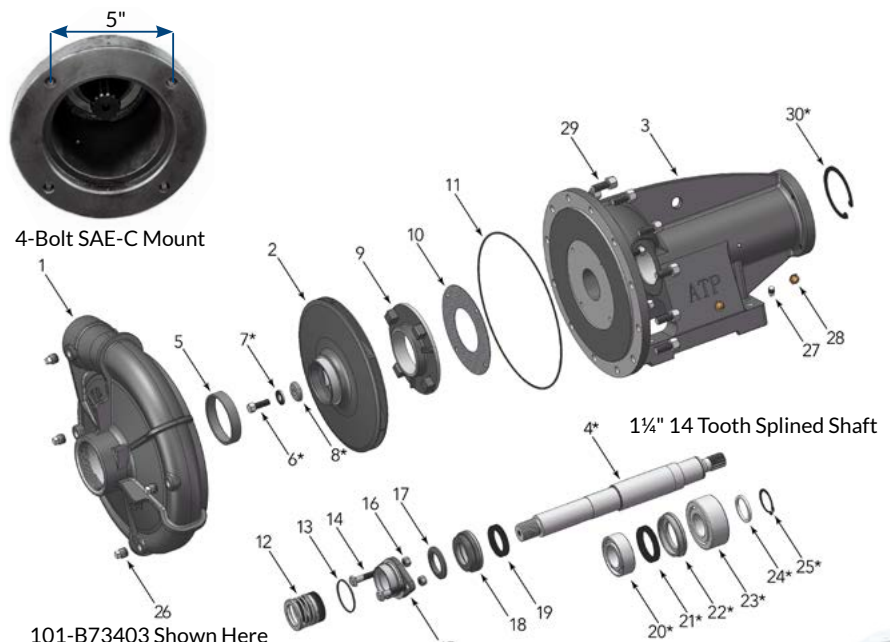

101-B73403 Shown Here

NEED PUMP SELECTION HELP? SEE PAGE 39

B4J 5 x 4 MECHANICAL SEAL PUMP (SPLINED)

COMPLETE WATER PUMP

CW, Flanged, Mech Seal

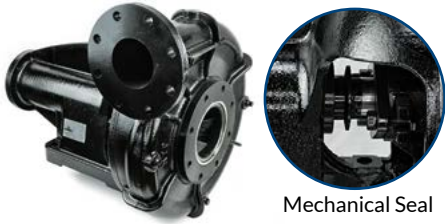

Mechanical Seal

TYPE	SKU
CW B4J Flanged Pump	101-B69743

IMPELLER

Cast Iron, Threaded



Clockwise (CW)

TYPE	SKU
CW B4J Impeller	112-L05976

SHAFT KIT

Shaft, Bearings, Lock Washer & Bolt



TYPE	SKU
CW B4J Splined Shaft Kit	111-B73051

ALL COMPONENTS

	PART NAME	SKU
1	Case, Volute	113-H03843
† 2	Impeller	112-L05976
3	Pump Bearing Frame	114-M05103
† * 4	Shaft Kit	111-B73051
† 5	Ring, Wearing	116-S02894
* 6	Screw, Impeller ½-13 x 1½"	116-S23623
* 7	Lock Washer	116-S23038
* 8	Washer, Impeller	116-S19275
† 9	Ring, Balance	116-S13591
† 10	Gasket, Balance Ring	116-S09943
† 11	Gasket, Volute	116-S06271
† 12	Seal, Mechanical Shaft	116-S32693
† 13	O-Ring	116-S26471
† 14	Bolt, Sq. Head ½-13 x 2-3/4" (2 Req.)	116-S23792
† 15	Retainer, Mechanical Seal	116-S11452
† 16	Nut, Hex ½-13 x 7/16" (2 Req.)	116-S23347
† 17	Slinger, Water	116-S10964
18	Inner Bearing Cap	116-M10200
† 19	Seal, Oil	116-S14765
* 20	Bearing, Ball	116-S15604
* 21	Seal, Oil	116-M10210
† * 22	Outer Bearing Cap	116-M10209
* 23	Bearing, Ball	116-M10184
* 24	Ring, Thrust	116-S06519
* 25	Ring, Retaining	116-S23016
26	Stud, 3/8-16 x 1½" (4 Req.)	116-S23995
27	Nut, Hex 3/8-16 (4 Req.)	116-S23103
28	Plug, Pipe 1/2 NPT (4 Req.)	116-S23717
29	Plug, Pipe 1/4 NPT	116-S23715
30	Fitting, Grease (2 Req.)	116-S23670
31	Capscrew, Hex 5/8-11 x 1-1/2" (12 Req.)	116-S26999
† * 32	Ring, Retaining	116-S23025
†	Pump Rebuild Kit	1011-B4JS

* Items included in shaft kit

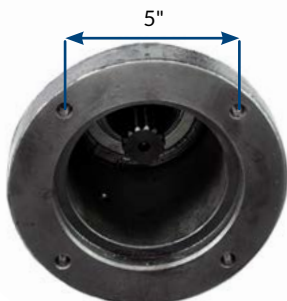

4-Bolt SAE-C Mount

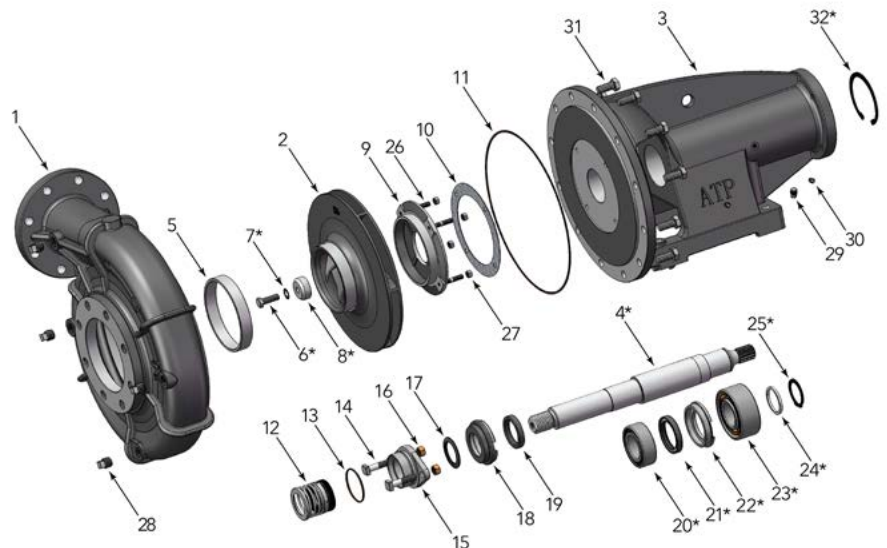

1¼" 14 Tooth Splined Shaft



Scan Here for Pump Selector!

B4J 5 x 4 ROPE SEAL PUMP (KEYED)

COMPLETE WATER PUMP

CW, Flanged, Rope Seal

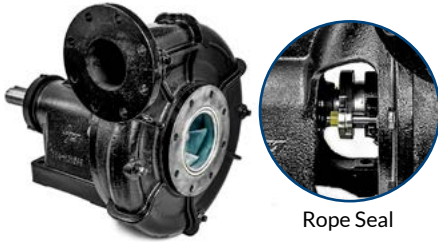

Rope Seal

TYPE	SKU
CW B4J Flanged Pump	101-B62321

IMPELLER

Cast Iron, Threaded



Clockwise (CW)

TYPE	SKU
CW B4J Impeller	112-L05976

SHAFT KIT

Shaft, Bearings, Washer, Bolt & Key



TYPE	SKU
CW B4J Keyed Shaft Kit	111-B07596

ALL COMPONENTS

	PART NAME	SKU
1	Volute, B4J, CW	113-H03843
† 2	Impeller, B4J, CW	112-L05976
3	Bearing Frame	114-H01599
† * 4	Shaft Kit, CW, 1-7/8" Keyed	111-B07596
† 5	Wearing Ring	116-S02894
* 6	Screw, Impeller 1/2-13 x 1-1/2"	116-S23623
* 7	Lock Washer	116-S23038
* 8	Impeller Washer	116-S19275
9	Balance Ring	116-S12315
† 10	Balance Ring Gasket	116-S09943
† 11	Volute Gasket	116-S06271
12	Throat Bushing	116-S18992
13	Stud, 3/8-16 x 1-3/8" (4 Req.)	116-S09942
† 14	Outer Bearing Cap	116-S35277
† 15	Metallic Ring	116-S13434
16	Lantern Ring	116-S18993
† 17	Packing Set (Set of 4 Rings)	116-S13436
† 18	Bolt, Sq. Head 1/2-13 x 2-3/4" (2 Req)	116-S23794
† 19	Packing Gland, Split	116-B82472
† 20	Nut, Hex 1/2-13 (2 Req)	116-S23347
† 21	Water Slinger	116-S10964
22	Inner Bearing Cap	116-S05928
* 23	Bearing	116-S15604
* 24	Bearing	116-S13396
* 25	Thrust Ring	116-S06519
* 26	Retaining Ring	116-S23016
27	Capscrew, Hex 5/8-11 x 1-1/2" (12 Req)	116-S26999
* 28	Key, 1/2 x 4" (8 Req)	116-S24214
29	Grease Fitting (2 Req)	116-S23670
30	Pipe Plug, 1/2" NPT (4 Req)	116-S23717
31	Nut, Hex 3/8-16"	116-S23103
†	Pump Rebuild Kit	1011-B4JR

* Items included in shaft kit



1-7/8" Keyed Shaft

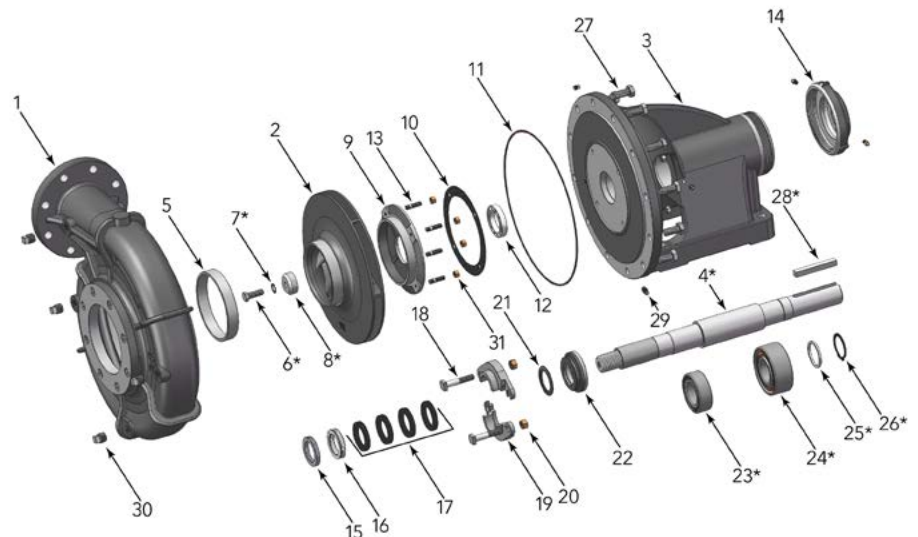

WATER PUMPS

B6Z HIGH VOLUME PUMP

COMPLETE WATER PUMP

CW, Flanged, Rope Seal

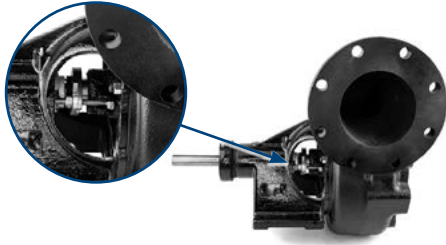

TYPE	SKU
CW B6Z Rope Seal Pump	101-B69501

COMPLETE WATER PUMP

CW, Flanged, Mechanical Seal

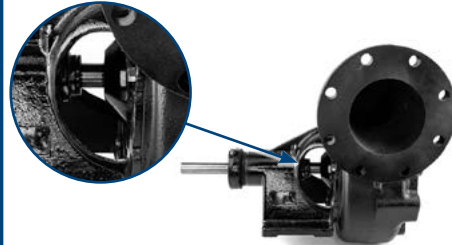

TYPE	SKU
CW B6Z Mech Seal Pump	101-B69500

COMPLETE WATER PUMP

CW, Flanged, Rope Seal, B6ZRL



Complete Pump



With modified impeller for use with electric motor



Power Frame

TYPE	SKU
CW B6ZRL Rope Seal Pump	101-B69504
CW B6ZRL Impeller	112-M04272
CW B6ZRL Power Frame	103-B69504

IMPELLER

Cast Iron, Threaded



Clockwise (CW)

TYPE	SKU
CW B6Z Impeller	112-M04186

SHAFT KIT

Shaft, Bearings, Lock Washer & Bolt

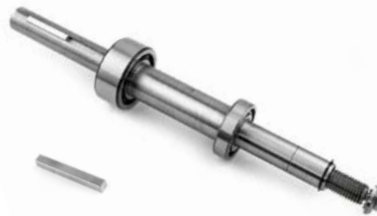

TYPE	SKU
CW B6Z Keyed Shaft Kit	111-B82184

ALL COMPONENTS (ROPE SEAL)

PART NAME	SKU
1 Volute, B6Z	113-H05065
2 Impeller B6Z, CW	112-M04186
3 Volute Gasket	116-S05126
4 Pump Frame, Rope Seal	114-H00553
5 Stud, 3/8-16 x 1-1/4"	116-S23944
6 Nut, Hex 3/8-16	116-S23103
7 Outer Bearing Cap	116-S19914
8 1/2" Pipe Plug	116-S23717
9 Rope Packing	116-S14022
10 Packing Bolt (2 req)	116-S23762
11 Split Packing Gland	116-B82468
12 Packing Nut (2 req)	116-S23343
13 Water Slinger	116-S12260
14 Inner Bearing Cap	116-S19033
*15 Shaft Sleeve (For Rope & Mech)	116-S39242
*16 Pump Shaft Kit (For Rope & Mech)	111-B82184
*17 1/4" Key	116-S24255
*18 Ball Bearing	116-S13270
*19 Ball Bearing	116-S13271
*20 Thrust Ring	116-S29218
*21 Retaining Snap Ring	116-S23010
*22 Screw, Impeller 3/8-16 x 1-3/4"	116-S23572
*23 Lock Washer	116-S23036
*24 Impeller Washer	116-S06314

MECHANICAL SEAL COMPONENTS

PART NAME	SKU
4 Pump Frame, Mechanical Seal	114-H04007
9M Mechanical Seal	116-S32690

* Items included in shaft kit

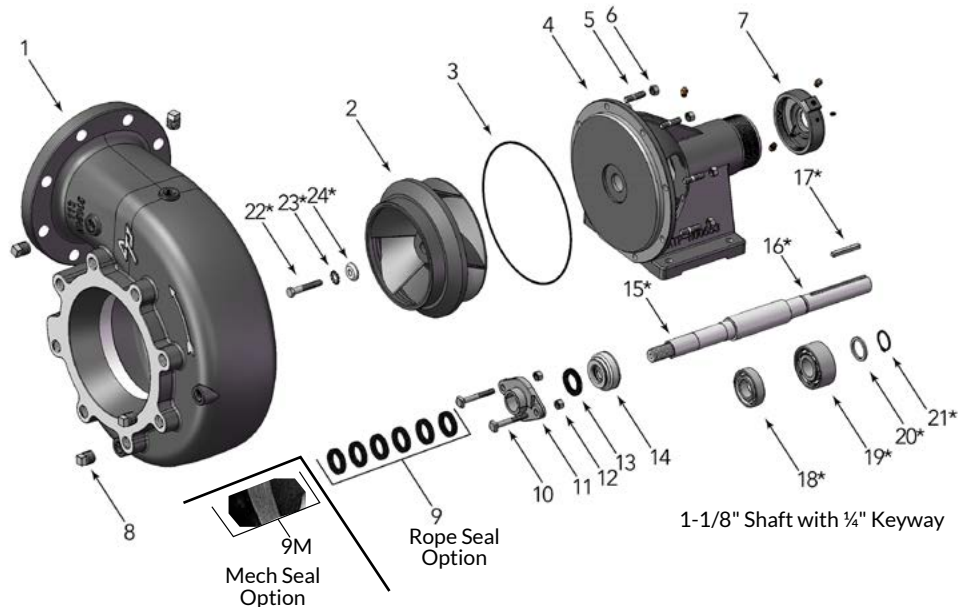

Our Standard 101-B69501 Rope Seal Version Shown Here



Scan Here for Pump Selector!

ACCESS TRUCK PARTS

NEED PUMP SELECTION HELP? SEE PAGE 39

STAINLESS STEEL 4 x 3 MECHANICAL SEAL PUMP (POTABLE)

COMPLETE WATER PUMP

CW, Flanged, Keyed, Mechanical Seal

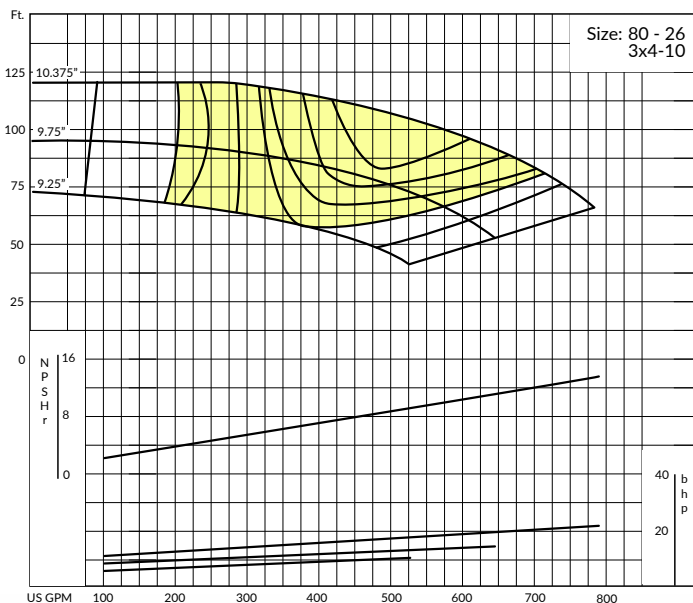

TYPE	SKU
NSF CW 316 Stainless Mech Seal Pump	101-XA80-26
NSF CCW 316 Stainless Mech Seal Pump	101-XA80-27
CW 304 Stainless Mech Seal Pump	101-XA80-26-1



NSF/ANSI STANDARD 61 CERTIFICATION AVAILABLE!
SAFE TO BE INSTALLED IN A POTABLE WATER SYSTEM FOR PUBLIC USE AND CONSUMPTION

ALL COMPONENTS

PART NAME	SKU
1 Shaft Kit	111-XA-35
2 Impeller, Stainless	112-XA80-26
3 Mechanical Seal	116-32MS
4 Abutment Ring	116-XA32
5 O-Ring	116-265.31
6 Pump Wear Ring	116-130
7 Bearing Cover	116-XA35BC
8 Seal	116-35.56.12
9 Gasket	116-123.80.012
10 Retaining Water Circle	116-32RR

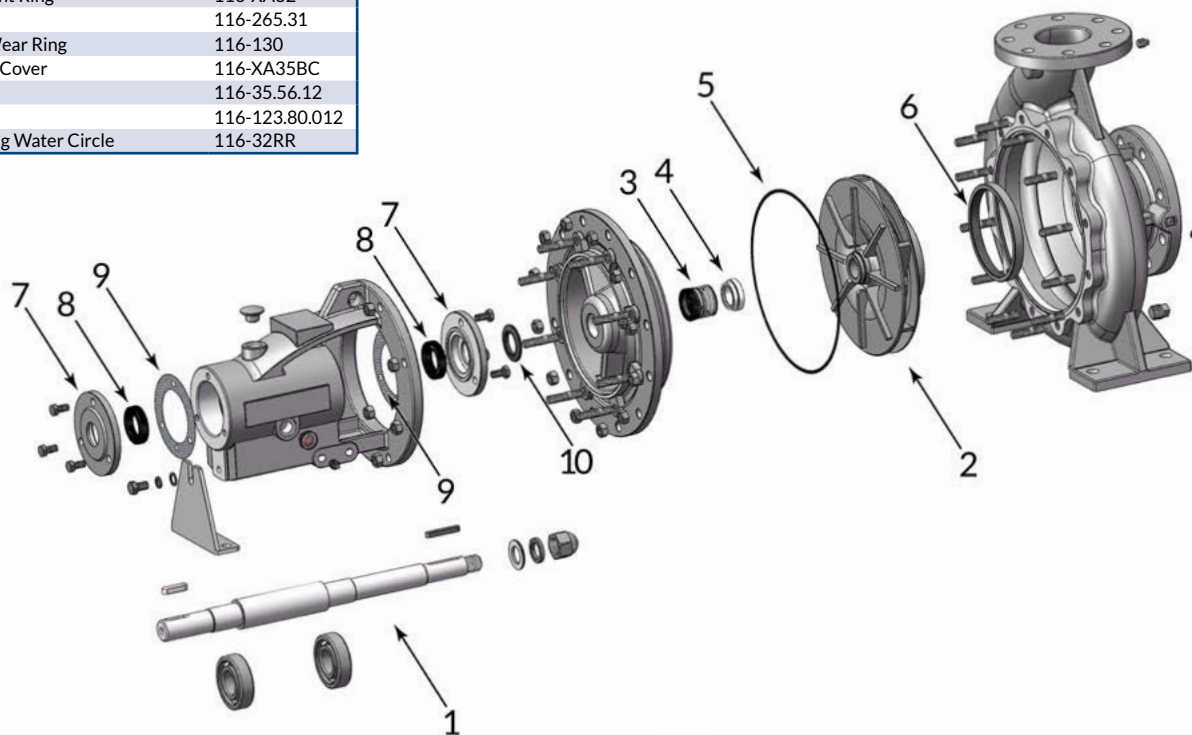

IN-LINE CONTROL VALVES

AIR OPERATED

CLA STYLE VALVE

Steel, Grooved



TYPE	SKU
3"	171-300GR

TEE VALVE

Aluminum, Grooved



TYPE	SKU
3"	195-300

HYDRAULIC

CLA STYLE VALVE

Aluminum, Threaded



TYPE	SKU
3"	171-300HYD

MANUAL VALVES

BUTTERFLY VALVE

Wafer Style, with Handle



TYPE	SKU
2½"	181B-250
3"	181B-300
4"	181B-400
6"	181B-600
10"	181B-1000
12"	181B-1200

BUTTERFLY VALVE

Grooved, with Handle



TYPE	SKU
2"	182-200
2½"	182-250
3"	182-300
4"	182-400
5"	182-500
6"	182-600

GATE VALVE

Brass, Threaded



TYPE	SKU
½"	184-050
1"	184-100
1¼"	184-125
1½"	184-150
2"	184-200
2½"	184-250
3"	184-300

CLA STYLE VALVE

Threaded



DES.	CONSTRUCTION	SKU
3"	Aluminum	171-300AL
2½"	Steel	171-250
3"	Steel	171-300

NORMALLY CLOSED VALVE

Aluminum, Grooved



TYPE	SKU
3"	177-300

DIAPHRAGM VALVE

Aluminum, NPT & Grooved



TYPE	SKU
2"NPT × 3"GRV	1722-200300G
2½"NPT × 3"GRV	1722-250300G

BUTTERFLY VALVE

Wafer Style



DES.	TYPE	SKU
2½"	Air Open/Close	173B-250-AA
3"	Air Open/Close	173B-300-AA
4"	Air Open/Close	173B-400-AA
6"	Air Open/Close	173B-600-AA
2½"	Spring Return	173B-250-SR
3"	Spring Return	173B-300-SR
4"	Spring Return	173B-400-SR
6"	Spring Return	173B-600-SR

DIAPHRAGM VALVE

Aluminum, Grooved



TYPE	SKU
3"	1721-300

DIAPHRAGM VALVE

Steel, Threaded



TYPE	SKU
3"	1722-300

BUTTERFLY VALVE

Grooved



DES.	TYPE	SKU
2½"	Air Open/Close	174B-250-AA
3"	Air Open/Close	174B-300-AA
4"	Air Open/Close	174B-400-AA
6"	Air Open/Close	174B-600-AA
2½"	Spring Return	174B-250-SR
3"	Spring Return	174B-300-SR
4"	Spring Return	174B-400-SR
6"	Spring Return	174B-600-SR

BUTTERFLY VALVE ACTUATORS



DES.	TYPE	SKU
3"	Air Open/Close	1731B-300-AA
4"	Air Open/Close	1731B-400-AA
6"	Air Open/Close	1731B-600-AA
2½"	Spring Return	1731B-250-SR
3"	Spring Return	1731B-300-SR
4"	Spring Return	1731B-400-SR

BALL VALVE

Brass, Threaded



TYPE	SKU
3/8"	183-0375
½"	183-050
¾"	183-075
1"	183-100
1½"	183-150
3"	183-300
¼" MPT × FPT	183-025-025
1¼" Full Port	183-125FP
1½" Full Port	183-150FP
3" Full Port	183-300FP

DEFLECTOR TYPE SPRAY HEADS



SLIP-OVER DEFLECTOR
Aluminum



TYPE	SKU
3"	211-300

ADJUSTABLE FAN SPRAY
Aluminum, Grooved



DES.	HEIGHT	SKU
3"	Short (4")	211-3-100
3"	Tall (6")	211-3-140

ADJUSTABLE PATTERN
Aluminum, Grooved



TYPE	SKU
3"	213-110

SLOTTED PIPE CAP
Iron, Threaded



TYPE	SKU
2"	215-200
2½"	215-250
3"	215-300

AIR OPERATED SPRAY HEAD VALVES

FIXED PATTERN
Aluminum, Threaded



DES.	HEIGHT	SKU
3"	Short	179-100602
3"	Tall	179-100601

ADJUSTABLE PATTERN
Aluminum, Grooved, Normally Closed



TYPE	SKU
3"	191-71300

AGM STYLE
Aluminum Body, Weld Mount



TYPE	SKU
3"	196-SV4105

HYDRAULIC

HYDRAULIC SPRAY HEAD VALVE
Aluminum Body, Weld Mount

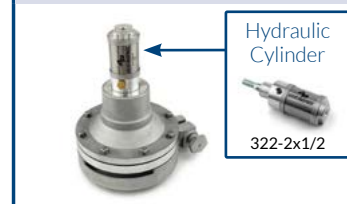

TYPE	SKU
3"	194-025610

HEAVY DUTY ADJUSTABLE
Aluminum, Weld Mount



Includes mounting plate, eccentric washers and mounting bolts.

TYPE	SKU
3"	193-300

MINI ADJUSTABLE
Aluminum, Grooved



TYPE	SKU
3"	197-QP-303

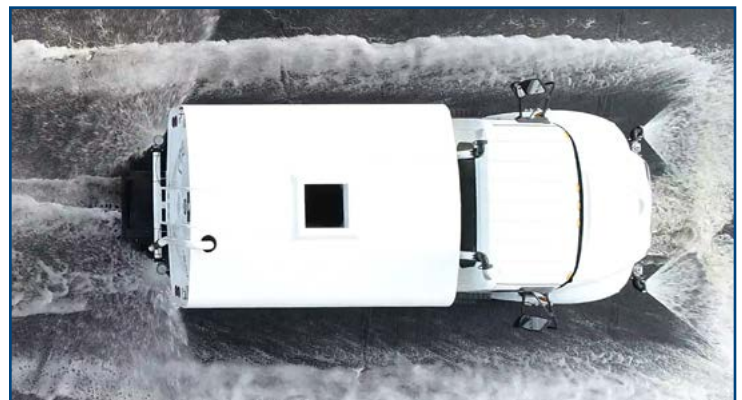

SIDE SPRAY HEADS

5" x 1/4" SLOT FIN SIDE SPRAY

5" x 1/4" SLOT FIN
Aluminum, Grooved



TYPE	SKU
3"	212-300

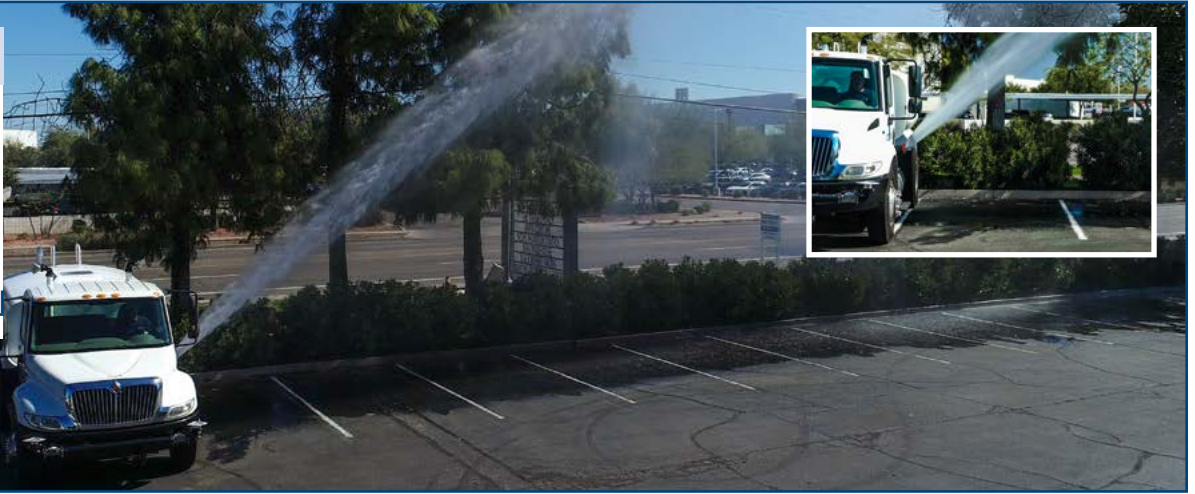

7" SLOT DUCKBILL SIDE SPRAY

7" x 1/4" SLOT DUCKBILL
Aluminum, Grooved



TYPE	SKU
3"	212-7-300



5" SLOT DUCKBILL SIDE SPRAY

5" x 1/4" SLOT DUCKBILL
Aluminum, Grooved



TYPE	SKU
3"	212-5-300



90° SIDE SPRAY

4¾" x ¾" SLOT 90°
Aluminum, Grooved



TYPE	SKU
3"	214-300



SIDE SPRAY HEAD

SIDE SPRAY HEAD
Aluminum, Grooved/Threaded



TYPE	SKU
3"Grv/2.5"FNPT	212-300250THD
2.5" MNPT only	212-250THD



STREET FLUSER

6" x ¾" SLOT STREET FLUSER
Steel, Threaded



TYPE	SKU
2"	214-SVNOZFR-2

7" x ¾" SLOT DUCKBILL
Aluminum, Grooved



TYPE	SKU
3"	214-300-7x3/32



SPRAY HEAD KITS

DIAPHRAGM VALVE ASSEMBLIES

FIN SIDE SPRAY HEAD

Aluminum Diaphragm Valve, Grooved



TYPE	SKU
1-6 3" FULL KIT - W/ FIN SIDE SPRAY	1721A-212-300
1 3" Grooved x PE Nipple	246-300
2 3" Angle Pad Groove Coupling	251-300ZFG
3 3" Grooved In-Line Valve	1721-300
4 3" 90° Groove Elbow	241-90300
5 3" Flex Groove Coupling	251-300FG
6 Side Spray Head (Fin)	212-300

DUCKBILL FLUSHER HEAD

Aluminum Diaphragm Valve, Grooved



TYPE	SKU
1-6 3" FULL KIT - W/ DUCKBILL FLUSHER HEAD	1721A-7X3/32
1 3" Grooved x PE Nipple	246-300
2 3" Angle Pad Groove Coupling	251-300ZFG
3 3" Grooved In-Line Valve	1721-300
4 3" 90° Groove Elbow	241-90300
5 3" Flex Groove Coupling	251-300FG
6 Flusher Head, 7" x 3/32" Slot	214-300-7x3/32

ADJUSTABLE DEFLECTOR SPRAY HEAD

Aluminum Diaphragm Valve, Grooved



TYPE	SKU
1-6A 3" FULL KIT - W/ SHORT DEFLECTOR	1721A-211-100
1-6B 3" FULL KIT - W/ TALL DEFLECTOR	1721A-211-140
1 3" Grooved x PE Nipple	246-300
2 3" Angle Pad Groove Coupling	251-300ZFG
3 3" Grooved In-Line Valve	1721-300
4 3" 90° Grooved Elbow	241-90300
5 3" Flex Groove Coupling	251-300FG
6a Short (4") Deflector Spray Head	211-3-100
6b Tall (6") Deflector Spray Head	211-3-140

90° FLUSHER HEAD

Aluminum Diaphragm Valve, Grooved



TYPE	SKU
1-6 3" FULL KIT - W/ 90° FLUSHER HEAD	1721A-214-300
1 3" Grooved x PE Nipple	246-300
2 3" Angle Pad Groove Coupling	251-300ZFG
3 3" Grooved In-Line Valve	1721-300
4 3" 90° Grooved Elbow	241-90300
5 3" Flex Groove Coupling	251-300FG
6 90° Flusher Side Spray Head	214-300

THREADED CLA STYLE VALVE ASSEMBLIES

FIN SIDE SPRAY HEAD

CLA Style Valve, Threaded



TYPE	SKU
1-6 3" FULL KIT - ALUMINUM VALVE W/ FIN SIDE SPRAY	171A-212-300AL
1-6 3" FULL KIT - STEEL VALVE W/ FIN SIDE SPRAY	171A-212-300
1 3" Aluminum CLA Style Valve	171-300AL
1 3" Steel CLA Style Valve	171-300
2 3" Grooved x Thread Nipple	245-300
3 3" Angle Pad Groove Coupling	251-300ZFG
4 3" 90° Groove Elbow	241-90300
5 3" Flex Groove Coupling	251-300FG
6 3" Side Spray Head (Fin)	212-300

ADJUSTABLE DEFLECTOR SPRAY HEAD

CLA Style Valve, Threaded

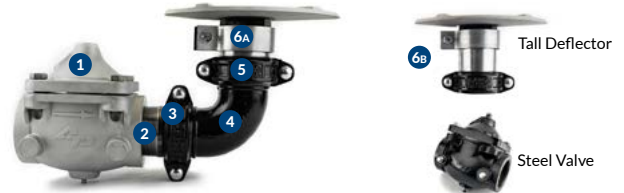

TYPE	SKU
1-6A 3" FULL KIT - ALUMINUM VALVE W/ SHORT DEFLECTOR	171A-211-100AL
1-6B 3" FULL KIT - ALUMINUM VALVE W/ TALL DEFLECTOR	171A-211-140AL
1-6A 3" FULL KIT - STEEL VALVE W/ SHORT DEFLECTOR	171A-211-100
1-6B 3" FULL KIT - STEEL VALVE W/ TALL DEFLECTOR	171A-211-140
1 3" Aluminum CLA Style Valve	171-300AL
1 3" Steel CLA Style Valve	171-300
2 3" Grooved x Thread Nipple	245-300
3 3" Angle Pad Grooved Coupling	251-300ZFG
4 3" 90° Grooved Elbow	241-90300
5 3" Flex Grooved Coupling	251-300FG
6a Tall (6") Deflector Spray Head	211-3-140
6b Short (4") Deflector Spray Head	211-3-100

TEE VALVE ASSEMBLIES

ADJUSTABLE PATTERN SPRAY HEAD

Aluminum Valve, Grooved



TYPE	SKU
1-5 3" FULL KIT - W/ ADJUSTABLE NOZZLE	195A-8304
1 3" Tee Valve	195-300
2 3" Angle Pad Groove Coupling	251-300ZFG
3 3" Grooved x PE Nipple	246-300
4 3" Flex Groove Coupling	251-300FG
5 3" Adjustable Spray Head	213-110

90° SIDE SPRAY HEAD

Aluminum Valve, Grooved



TYPE	SKU
1-5 3" FULL KIT - W/ 90° STREET FLUSHER SPRAY HEAD	195A-6304
1 3" 90° Street Flusher Spray Head	214-300
2 3" Flex Groove Coupling	251-300FG
3 3" Tee Valve	195-300
4 3" Angle Pad Groove Coupling	251-300ZFG
5 3" Grooved x PE Nipple	246-300

ADJUSTABLE DEFLECTOR SPRAY HEAD

Aluminum Valve, Grooved



TYPE	SKU
1-5A 3" FULL KIT - W/ SHORT DEFLECTOR HEAD	195A-211-100
1-5B 3" FULL KIT - W/ TALL DEFLECTOR HEAD	195A-211-140
1 3" Tee Valve	195-300
2 3" Angle Pad Groove Coupling	251-300ZFG
3 3" Grooved x PE Nipple	246-300
4 3" Flex Groove Coupling	251-300FG
5a Deflector Spry Head, Short	211-3-100
5b Deflector Spry Head, Tall	211-3-140

FIN SIDE SPRAY / FLUSHER HEAD

Aluminum Valve, Grooved



TYPE	SKU
1-5A 3" FULL KIT - W/ 7" SLOT DUCKBILL SIDE SPRAY	195A-8854
1-5B 3" FULL KIT - W/ 7" x 3/32" SLOT FLUSHER SPRAY	195A-7304
1-5C 3" FULL KIT - W/ FIN SIDE SPRAY	195A-212
1 3" Tee Valve	195-300
2 3" Angle Pad Groove Coupling	251-300ZFG
3 3" Grooved x PE Nipple	246-300
4 3" Flex Groove Coupling	251-300FG
5a 7" Slot Duck Bill Side Spray Head	212-7-300
5b 7" x 3/32" Slot Flusher Head	214-300-7x3/32
5c Side Spray Head (Fin Style)	212-300

90° FIN SIDE SPRAY / FLUSHER HEAD

Aluminum Valve, Grooved



TYPE	SKU
1-6A 3" FULL KIT - W/ 7" SLOT DUCKBILL SIDE SPRAY	195A-8174
1-6B 3" FULL KIT - W/ 7" x 3/32" SLOT FLUSHER HEAD	195A-3484
1-6C 3" FULL KIT - W/ FIN SIDE SPRAY HEAD	195A-2123
1 3" Tee Valve	195-300
2 3" Angle Pad Groove Coupling	251-300ZFG
3 3" Grooved x PE Nipple	246-300
4 3" 90° Grooved Elbow	241-90300
5 3" Flex Groove Coupling	251-300FG
6a 7" Slot Duck Bill Side Spray Head	212-7-300
6b 7" x 3/32" Slot Flusher Head	214-300-7x3/32
6c Side Spray Head (Fin Style)	212-300

GROOVED SPRAY HEAD ASSEMBLY

ADJUSTABLE PATTERN SPRAY HEAD VALVE

Aluminum Spray Head Valve, Grooved, Normally Closed



* Optional Electric Version of 191 Grooved Spray Head

PART	SKU
1-4 3" FULL KIT - SPRAY HEAD KIT	191A-71A3
1-4* 3" FULL KIT - ELECTRIC SPRAY HEAD KIT - 12V	192A-71A3-12
1-4* 3" FULL KIT - ELECTRIC SPRAY HEAD KIT - 24V	192A-71A3-24
1 3" Grooved x Weld Nipple	246-300
2 3" Angle Pad Groove Coupling	251-300ZFG
3 3" 90° Grooved Elbow	241-90300
4 Grooved Spray Head	191-71300

3" GROOVED SPRAY HEAD VALVE REBUILD KIT

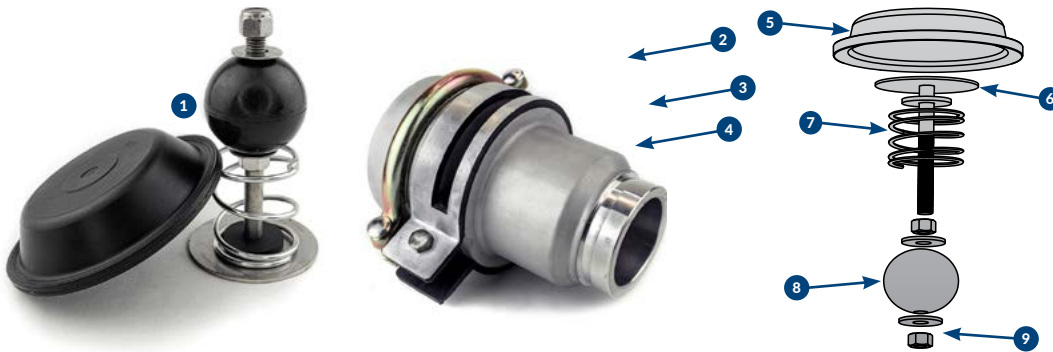

	SKU	DESCRIPTION
1(5-9)	1911-71A-KIT	COMPLETE REBUILD KIT
2	1911-CAP	Valve Cap, 3" Spray Head
3	1951-1016-6	Valve Clamp, 1016 -6, T-16
4	1911-BAND	Valve Spray Adjuster Band
5	1911-T16	Valve Diaphragm, T-16
6	1911-QE716	Valve Stem
7	1911-QE715	Valve Spring
8	1911-QE714	Valve Replacement Ball
9	1911-MISC	Positioning Nuts / Washers

3" HEAVY DUTY SPRAY HEAD VALVE REBUILD KIT



	SKU	DESCRIPTION
1(5-10)	1931-300KIT	COMPLETE REBUILD KIT
2	1931-300213A	Heavy Duty Spray Head Spring
3	1931-302912	Valve Adjusting Ring Knob
4	1931-300216	Valve Adjuster Ring
5	1711-300-1	Valve Diaph Kit Bolt, 3"
6	1711-625WSH	5/8" Flat Washer SAE
7a,b,c	1711-300-345	Valve Retainer Disc SET
8	1711-113N6001	O-Ring 113
9	1931-300208	Valve Diaphragm, 3" Mega
10	1711-300-5	Valve Kit Seat, 3"
11	1931-025771	Mounting Plate
12	1931-354502	Mounting O-Ring
13	1931-ME410042	Eccentric Washer
14	1911-QEV-025	3/4" Quick Exhaust Valve

3" GROOVED TEE VALVE REBUILD KIT

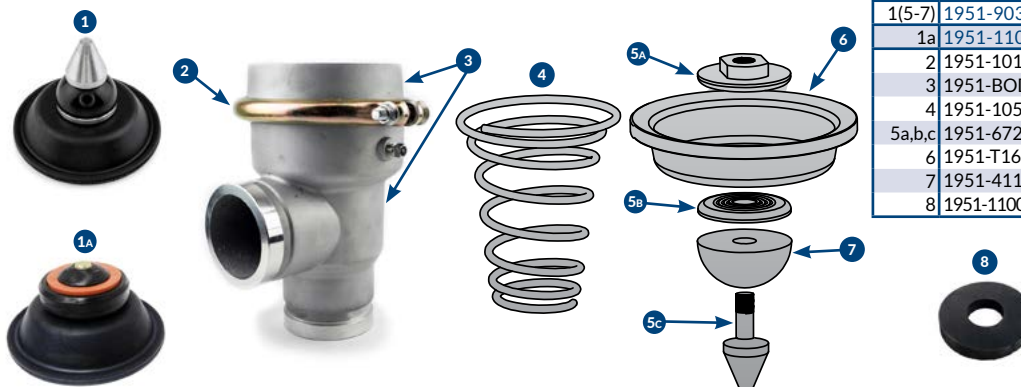

	SKU	DESCRIPTION
1(5-7)	1951-9030KIT	COMPLETE REBUILD KIT NO SPRING (OLD)
1a	1951-1100KIT	COMPLETE REBUILD KIT NO SPRING (NEW)
2	1951-1016-6	Valve Clamp, 1016-6, T-16
3	1951-BODY	195 Valve Body and Cap
4	1951-1056SPG	Spring, Tee Valve
5a,b,c	1951-6720	Valve, Aluminum Assembly
6	1951-T16-P	Diaphragm, T-16, Punched
7	1951-4116	Valve Seat (Ball)
8	1951-1100-SEAT	Seat, Tee Valve (New)

THREADED CLA STYLE VALVE REBUILD KIT



	SKU	DESCRIPTION	SIZE
1(5-7)	1711-250-KIT	COMPLETE REBUILD KIT	2-1/2"
1(5-7)	1711-300-KIT	COMPLETE REBUILD KIT	3"
2	1711-250SPG	Valve Spring	2-1/2"
2	1711-300SPG	Valve Spring	3"
3a	1711-BONNET-AL	Valve Bonnet, Aluminum	3"
3s	1711-BONNET-STL	Valve Bonnet, Steel	3"
4a	1711-BODY-AL	Valve Body, Aluminum	3"
4s	1711-BODY-STL	Valve Body, Steel	3"
5	1711-300-1	Valve Kit Bolt	3"
6	1711-625WSH	5/8" Flat Washer	3"
7a,b,c	1711-300-345	Valve Retainer Disc	3"
8	1711-113N6001	O-Ring, 113	3"
9	1711-250-7	Valve Diaphragm	2-1/2"
9	1711-300-7	Valve Diaphragm	3"
10	1711-250-5	Valve Seat	2-1/2"
10	1711-300-5	Valve Seat	3"

3" GROOVED NORMALLY CLOSED INLINE VALVE REBUILD KIT



* Gravity Valve Only!

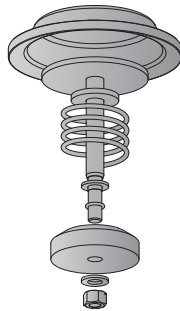

SKU	DESCRIPTION
1771-NCIV-KIT	COMPLETE REBUILD KIT



F/E VALVE REBUILD KIT

SKU	DESCRIPTION
1-2	1781-KIT COMPLETE REBUILD KIT
1	1781-A3510 F/E Sales Valve Diaphragm
2	1781-NEOSEAL F/E Sales Valve Seat (Seat 4" x 1/2")



3" DOME DIAPHRAGM VALVE REBUILD KIT

SKU	DESCRIPTION
1723-300	DOMED DIAPHRAGM VALVE



AGM STYLE VALVE REBUILD KIT

SKU	DESCRIPTION
1-4	1961-SV410055-S COMPLETE REBUILD KIT W/ SPRING
1-3	1961-SV410055 COMPLETE REBUILD KIT NO SPRING
5	1961-SV4105-INS COMPLETE INSERT KIT NO SPRING
1	1961-SV410033 Valve Seat Ring
2	1961-SPRING Valve Spring
3	1961-SV410038 Valve Seat
4	1961-SV410035 Valve Diaphragm



3" THREADED VALEW STYLE SPRAY HEAD REBUILD KIT



SKU	DESCRIPTION
1-3	1791-KIT COMPLETE REBUILD KIT
1	1911-T16 Valve Diaphragm, T-16
2	1791-100606 Valve Spring Retain Plate, Valew
3	1791-100607 Valve Spring
4	1911-CAP Valve Cap
5	1951-1016-6 Valve Clamp, T-16
6	1791-101-103 Valve Body, Tall
7	1791-101-104 Valve Body, Short

GROOVE COUPLINGS

GROOVE COUPLINGS

RIGID COUPLINGS

Epoxy Coated Ductile Iron



TYPE	SKU
1"	251-100RG
1½"	251-150RG
2"	251-200RG
2½"	251-250RG
3"	251-300RG
4"	251-400RG
6"	251-600RG
8"	251-800RG

FLEXIBLE COUPLINGS

Epoxy Coated Ductile Iron



TYPE	SKU
2"	251-200FG
2½"	251-250FG
3"	251-300FG
4"	251-400FG

COUPLING GASKETS

EPDM Rubber



TYPE	SKU
1"	252-100
1½"	252-150
2"	252-200
2½"	252-250
3"	252-300
4"	252-400
5"	252-500
6"	252-600
8"	252-800

ANGLE PAD COUPLINGS

Epoxy Coated Ductile Iron



TYPE	SKU
2"	251-200ZFG
2½"	251-250ZFG
3"	251-300ZFG
4"	251-400ZFG

COUPLING GASKETS

Buna Rubber, Fuel Rated



TYPE	SKU
1"	253-100
1½"	253-150
2"	253-200
2½"	253-250
3"	253-300
4"	253-400
8"	253-800

PUSH ON GASKET

EPDM Rubber



TYPE	SKU
2.5"	252-250POC
3"	252-300POC
4"	252-400POC
4" x 3"	252-400x300

REDUCING COUPLINGS

Epoxy Coated Ductile Iron



TYPE	SKU
2½" x 2"	251-250x200
3" x 2"	251-300x200
3" x 2½"	251-300x250
3½ x 3"	251-350x300
4" x 3"	251-400x300
5" x 4"	251-500x400
3½" x 3"	251-350x300

REDUCING GASKETS

EPDM Rubber



TYPE	SKU
2½" x 2"	252-250x200
3" x 2"	252-300x200
3" x 2½"	252-300x250
4" x 3"	252-400x300

PUSH ON COUPLINGS

EPDM Rubber (Angle Pad)



TYPE	SKU
2.5"	251-250POC
3"	251-300POC
4"	251-300POC
6"	251-600POC

HINGED COUPLING

Painted Ductile Iron



TYPE	SKU
2½"	251-250-HINGE
3"	251-300-HINGE
4"	251-400-HINGE

PUSH ON COUPLING

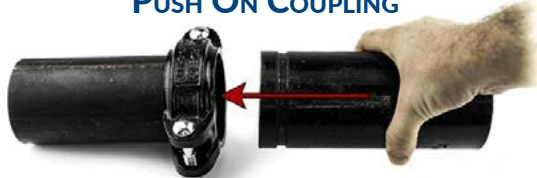

These couplings allow for quick installation and removal of grooved pipes in just seconds—no need for disassembly.

COUPLING VARIATIONS



FLEXIBLE COUPLINGS

These make alignment easier and help preserve the life of your pipes & pump.

RIGID COUPLINGS

These allow for very little movement for straighter alignment with less sag.

ANGLE PAD COUPLINGS

These allow no flex in the pipe connection, best for unsupported areas of pipe & spray heads.

GROOVE ELBOWS

90° SHORT RADIUS
Epoxy Coated Ductile Iron



TYPE	SKU
3"	241-90300SRG
3" Galvanized	241-90300SRG-G
4"	241-90400SRG

45°
Epoxy Coated Ductile Iron



TYPE	SKU
2½"	241-45250
3"	241-45300
3" Galvanized	241-45300-G
4"	241-45400

90°
Aluminum



TYPE	SKU
3"	241-90300AL

90°
Epoxy Coated Ductile Iron



TYPE	SKU
2"	241-90200
2½"	241-90250
3"	241-90300
3" Galvanized	241-90300-G
4"	241-90400
4" Galvanized	241-90400-G

90° GROOVE x THREAD
Epoxy Coated Ductile Iron



TYPE	SKU
2½"	242-90250
3"	242-90300

GROOVE TEES, CROSS & CAPS

SHORT RADIUS TEE
Epoxy Coated Ductile Iron



TYPE	SKU
4"	243-400SR
4" Galvanized	243-400SR-G

REDUCING TEE
Epoxy Coated Ductile Iron



TYPE	SKU
3" x 3" x 2"	243-300x200
3" x 3" x 2½"	243-300x250
4" x 4" x 3"	243-400x300
4" x 4" x 3" Galvanized	243-400x300-G

TEE
Epoxy Coated Ductile Iron



TYPE	SKU
2½"	243-250
3"	243-300
3" Galvanized	243-300-G

CROSS
Epoxy Coated Ductile Iron



TYPE	SKU
3"	248-300

CAP
Epoxy Coated Ductile Iron



TYPE	SKU
2"	247-200
2½"	247-250
3"	247-300
4"	247-400
3"	247-300
4"	247-400



SWIVELS

STYLE 20 - STRAIGHT
Aluminum or Cast Iron, NPT



TYPE	SKU
1½" Aluminum	273-125
1½" Aluminum	273-150
1½" Cast Iron	273-150CI
3" Aluminum	273-300
4" Aluminum	273-400

STYLE 30 - 90°
Cast Iron or Aluminum, NPT



TYPE	SKU
1½" Cast Iron	271-90150CI
3" Cast Iron	271-90300CI
4" Aluminum	271-90400

STYLE 40 - 180°
Aluminum, NPT



TYPE	SKU
3"	272-180300
4"	272-180400

ELECTRIC STRAIGHT SWIVEL
12V, Grooved, Threaded



Control box & harness included

TYPE	SKU
3" Grooved, 2½" Threaded	273-RJ65

GROOVE NIPPLES

GROOVE x NPT Schedule 40 Steel



TYPE	SKU
1½"	245-150
2"	245-200
2½"	245-250
3"	245-300
4"	245-400
2" x 4"	245-200x400
2½" x 4"	245-250x400
3" x 4"	245-300x400
3" x 6"	245-300x600
3" x 8"	245-300x800
4" x 6"	245-400x600
3" Galvanized	245-300-G

GROOVE x WELD Schedule 40 Steel



TYPE	SKU
2"	246-200
2½"	246-250
2½" x 6"	246-250x600
3"	246-300
3" x 6"	246-300x600
3" x 8"	246-300x800
4"	246-400
4" x 6"	246-400x600
4" x 8"	246-400x800
5"	246-500

OTHER NIPPLES

THREAD x HOSE BARB NIPPLE Plated Steel, NPT



TYPE	SKU
¾"	238-075
½"	238-050
1"	238-100
1¼"	238-125
1¼" x 1½"	238-125x150
1½"	238-150
2"	238-200
2½"	238-250
3"	238-300
4"	238-400

THREADED CLOSE NIPPLE Schedule 40 Steel, NPT



TYPE	SKU
¼"	236-025CL
½"	236-050CL
¾"	236-075CL
1¼"	236-125CL
1½"	236-150CL
2"	236-200CL
2½"	236-250CL
3"	236-300CL
4"	236-400CL

GROOVE x NOTCH Malleable Iron



TYPE	SKU
2½"	249-250
3"	249-300

GROOVE x HOSE BARB Plated Steel



TYPE	SKU
1½"	244-150
2"	244-200
2½"	244-250
3"	244-300
4"	244-400

WELD x HOSE BARB NIPPLE Schedule 40 Steel



TYPE	SKU
2½"	237-250
3"	237-300
4"	237-400

THREADED NIPPLE Schedule 40 Steel, NPT



TYPE	SKU
1" x 6"	236-100x600
1½" x 6"	236-150x600
2" x 4"	236-200x400
2" x 6"	236-200x600
2" x 8"	236-200x800
2½" x 4"	236-250x400
2½" x 6"	236-250x600
2½" x 8"	236-250x800
3" x 4"	236-300x400
3" x 6"	236-300x600
3" x 8"	236-300x800
3" x 10"	236-300x1000
3" x 12"	236-300x1200
4" x 6"	236-400x600
4" x 8"	236-400x800
4" x 10"	236-400x1000
4" x 12"	236-400x1200

GROOVE x GROOVE Schedule 40 Steel



TYPE
Custom Lengths Available

GROOVE REDUCERS

GROOVE x GROOVE Painted Ductile Iron



TYPE	SKU
3" x 2½"	256-300x250
4" x 3"	256-400x300

GROOVE x THREAD Painted Ductile Iron



TYPE	SKU
3" x 2½"	248-300x250
3" x 2"	248-300x200

THREAD x WELD NIPPLE Schedule 40 Steel



TYPE	SKU
1"	239-100
1½"	239-150
2½"	239-250
3"	239-300
3" x 6"	239-300x600
3" x 8"	239-300x800
4"	239-400

ELBOWS

90° SHORT RADIUS WELD ELBOW Schedule 40 Steel



TYPE	SKU
2½"	231-90250SR
3"	231-90300SR

45° WELD ELBOW Schedule 40 Steel



TYPE	SKU
2½"	231-45250
3"	231-45300
4"	231-45400

90° WELD ELBOW Schedule 40 Steel



TYPE	SKU
2½"	231-90250
3"	231-90300
4"	231-90400
5"	231-90500

90° THREADED ELBOW Malleable Iron, NPT



TYPE	SKU
1¼"	232-90125
1½"	232-90150
2½"	232-90250
3"	232-90300
4"	232-90400

45° THREADED ELBOW Malleable Iron, NPT



TYPE	SKU
2½"	232-45250
3"	232-45300
4"	232-45400

90° STREET ELBOW Malleable Iron, NPT



TYPE	SKU
¾"	233-90075
1¼"	233-90075
1½"	233-90150
2"	233-90200
2½"	233-90250
3"	233-90300
4"	233-90400

TEES

THREADED TEE Malleable Iron, NPT



TYPE	SKU
2½"	235-250T
3"	235-300T
4"	235-400T

WELD TEE Schedule 40 Steel



TYPE	SKU
2"	234-200T
2½"	234-250T
3"	234-300T
4"	234-400T

COUPLINGS / REDUCERS

REDUCER Schedule 40 Steel



TYPE	SKU
3" x 2"	2316-300x200
3" x 2½"	2316-300x250
4" x 3"	2316-400x300
5" x 4"	2316-500x400

BELL REDUCER Malleable Iron, NPT



TYPE	SKU
½" x ¼"	2315-050x025
2½" x 2"	2315-250x200
3" x 2"	2315-300x200
3" x 2½"	2315-300x250
4" x 3"	2315-400x300

HEX BUSHINGS Malleable Iron, NPT



(please call for other sizes)

TYPE	SKU
½" x ¼"	2317-050x025
¾" x 1½"	2317-075x050
1½" x 1"	2317-150x100
1½" x 1¼"	2317-150x125
2½" x ½"	2317-250x050
2½" x 2"	2317-250x200
3" x 1½"	2317-300x150
3" x 2"	2317-300x200
3" x 2½"	2317-300x250
4" x 3"	2317-400x300

THREADED CAP Malleable Iron, NPT



TYPE	SKU
1½"	2311-150
2"	2311-200
2½"	2311-250
3"	2311-300
4"	2311-400

MERCHANT COUPLING Malleable Iron, NPT



TYPE	SKU
¾"	2318-025
3/8"	2318-0375
½"	2318-050
¾"	2318-075
1"	2318-100
1½"	2318-150
2"	2318-200
2½"	2318-250
3"	2318-300
4"	2318-400

ALUMINUM CAMLOCK FITTINGS

STYLE A
Male Cam / Female Threads



TYPE	SKU
1½"	262-150A
2"	262-200A
2½"	262-250A
3"	262-300A
4"	262-400A
5"	262-500A
6"	262-600A

STYLE B
Female Cam / Male Threads



TYPE	SKU
1½"	264-150B
2"	264-200B
2½"	264-250B
3"	264-300B
4"	264-400B
5"	264-500B
6"	264-600B

STYLE C
Female Cam / Hose Barb



TYPE	SKU
1½"	266-150C
2"	266-200C
2½"	266-250C
3"	266-300C
4"	266-400C
5"	266-500C
6"	266-600C

STYLE D
Female Cam / Female Threads



TYPE	SKU
1½"	263-150D
2"	263-200D
2½"	263-250D
3"	263-300D
4"	263-400D
5"	263-500D
6"	263-600D

STYLE E
Male Cam / Hose Barb



TYPE	SKU
1½"	265-150E
2"	265-200E
2½"	265-250E
3"	265-300E
4"	265-400E
5"	265-500E
6"	265-600E

STYLE F
Male Cam / Male Threads



TYPE	SKU
1½"	261-150F
2"	261-200F
2½"	261-250F
3"	261-300F
4"	261-400F
5"	261-500F
6"	261-600F

DUST PLUG
Male Cam



TYPE	SKU
1½"	268-150DP
2"	268-200DP
2½"	268-250DP
3"	268-300DP
4"	268-400DP
5"	268-500DP
6"	268-600DP

DUST CAP
Female Cam



TYPE	SKU
1½"	267-150DC
2"	267-200DC
2½"	267-250DC
3"	267-300DC
4"	267-400DC
5"	267-500DC
6"	267-600DC

CAMLOCK ELBOWS
Female Cam / Female Threads



TYPE	SKU
2½"	269-25090

CAMLOCK GASKETS
BUNA Rubber



TYPE	SKU
1½"	2671-150
2"	2671-200
2½"	2671-250
3"	2671-300

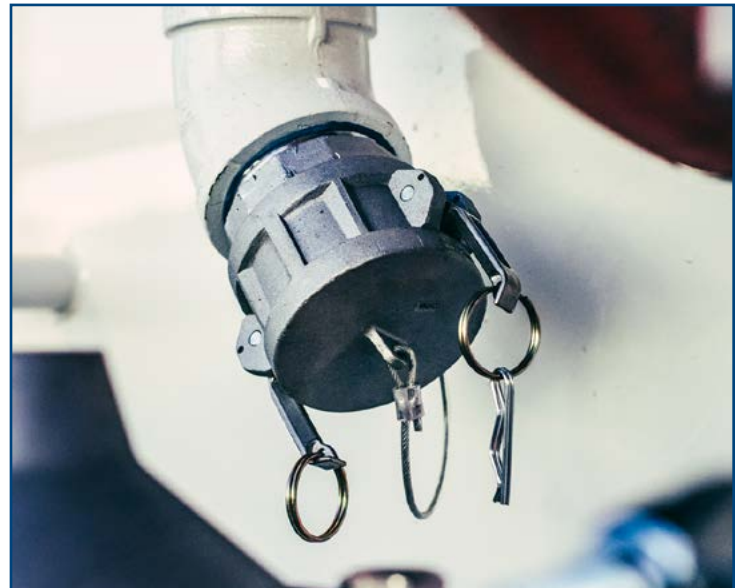

RAASM LUBE & FUEL HOSE REELS, GREASE PUMPS & MORE

WE NOW CARRY RAASM LUBE AND FUEL PRODUCTS!

Access Truck Parts is now an exclusive distributor of all genuine Raasm lube and fuel parts and equipment. Below is a sampling of parts we currently have in stock from the thousands of parts we are able to source directly from the manufacturer. From cutting-edge membrane pumps and oil hose reels to robust fuel transfer systems, Raasm's extensive catalog of products goes far beyond what we can include here. Experience the confidence that comes with choosing Access Truck Parts as your exclusive source for Raasm products. Expand your capabilities and equipment with the finest Raasm parts backed by the expertise and dedication of our team. For more information on the products we have available and how to order, please give one of our parts specialists a call at 877-583-5275.



AIR OPERATED DIAPHRAGM PUMPS

For pumping oils, antifreeze, diesel fuel & more



TYPE	SKU
1" Aluminum, 1:1 Comp, 45GPM, "NBR" Membrane	401-3CC/26111NHH-55
½" Poly / Alum 1:1 Comp, "NBR" Membrane	401-2BC/16117NH5-55
½" Poly / Alum 1:1 Comp, 15.8 GPM, Dual Inlet, NBR	401-2BH/16117NH52-55
¾" 18.5 GPM, Aluminum	401-32/2011NHH2-55

HOSE REELS

For delivering oils, grease, diesel, antifreeze & more



TYPE	SKU
50' x 3/8", Grease	402-8430.506-55
50' x ½", Oil	402-8430.402-55
50' x 1/2", Air / Water	402-8430.104-55
50' x 3/4", Series 540	402-8540.601-55
50' x 1", Series 540, Diesel	402-8540.603-55

PNEUMATIC PUMPS

For pumping oil, diesel, antifreeze & more directly from a container



TYPE	SKU
Series 238, 5:1, Oil, 5.50 gpm	403-36161-55
Series 238, 5:1, Oil, 5.50 gpm w/bung adapter	403-36167-55
Series 238, 50:1, Grease, 3.3 lb/min 120 lb container	403-62174-55
Series 238, 3:1, Oil, 4.40 gpm, "NBR" seals, 1" suction tube	403-35561-55

GREASE DRUM KITS

For pumping grease from a storage drum



TYPE	SKU
Grease Dispenser Kit w/pump, 120lb Drum	404-64143-55
Grease Drum Tie Down kit for pump with 1.18" downtube, 120lb Drum	4041-65709-55
Grease Drum Follower Plate, 120lb Drum, 13.2"-14.2" ID	4041-66370-55

DISPENSING VALVES

For dispensing oil, diesel, antifreeze & more



TYPE	SKU
½", Oil w/ digital meter	405-37754-55
1/4", Grease, Z-Swivel w/Flexible Extension	405-66889-55
1/2", Oil w/ Lever Locking Button	405-37738-55
1/2", Oil, Metered, w/ Lever Locking Button	405-37739-55

DIVERTER / FLOW VALVE

For extraction and discharge of oil, hydraulic fluid, antifreeze & more



TYPE	SKU
1" FNPT, 4-way Evac	406-38131-55

THE TEMPEST 12V/24V WATER CANNON

The TEMPEST water cannon



288-TSKD20-40SS

The Tempest 12V/24V electric water cannon is made from 304 stainless steel. A fully adjustable nozzle and integrated joystick change flow from straight stream to fog and turn 340° horizontal and 180° vertical. A plug and play control box and wiring harness make set up quick and easy.

Find all of The Tempest Water Cannon upgrades, addons, and replacement parts on our website

[AccessTruckParts.ca/tempest](https://www.AccessTruckParts.ca/tempest)

Spray Performance Chart

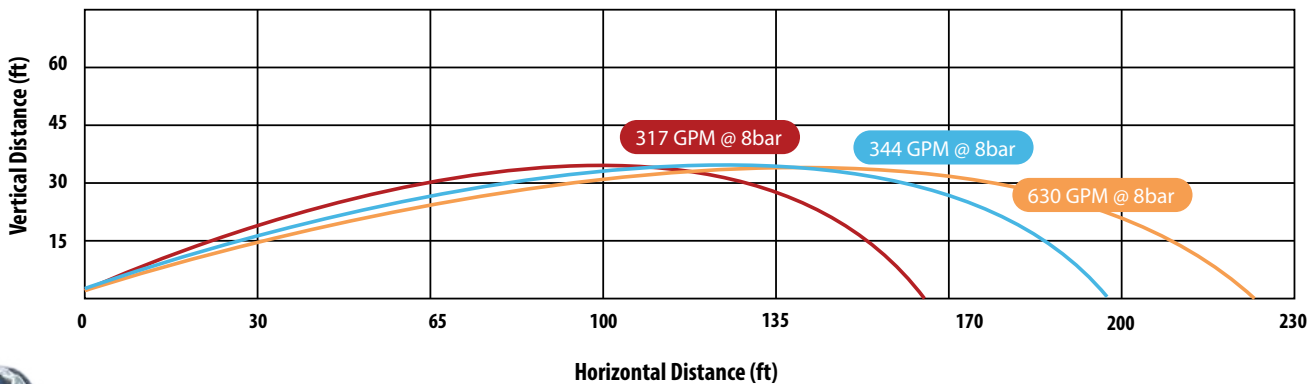

TEMPEST CANNON PARTS DIAGRAM



Find The Tempest Online!

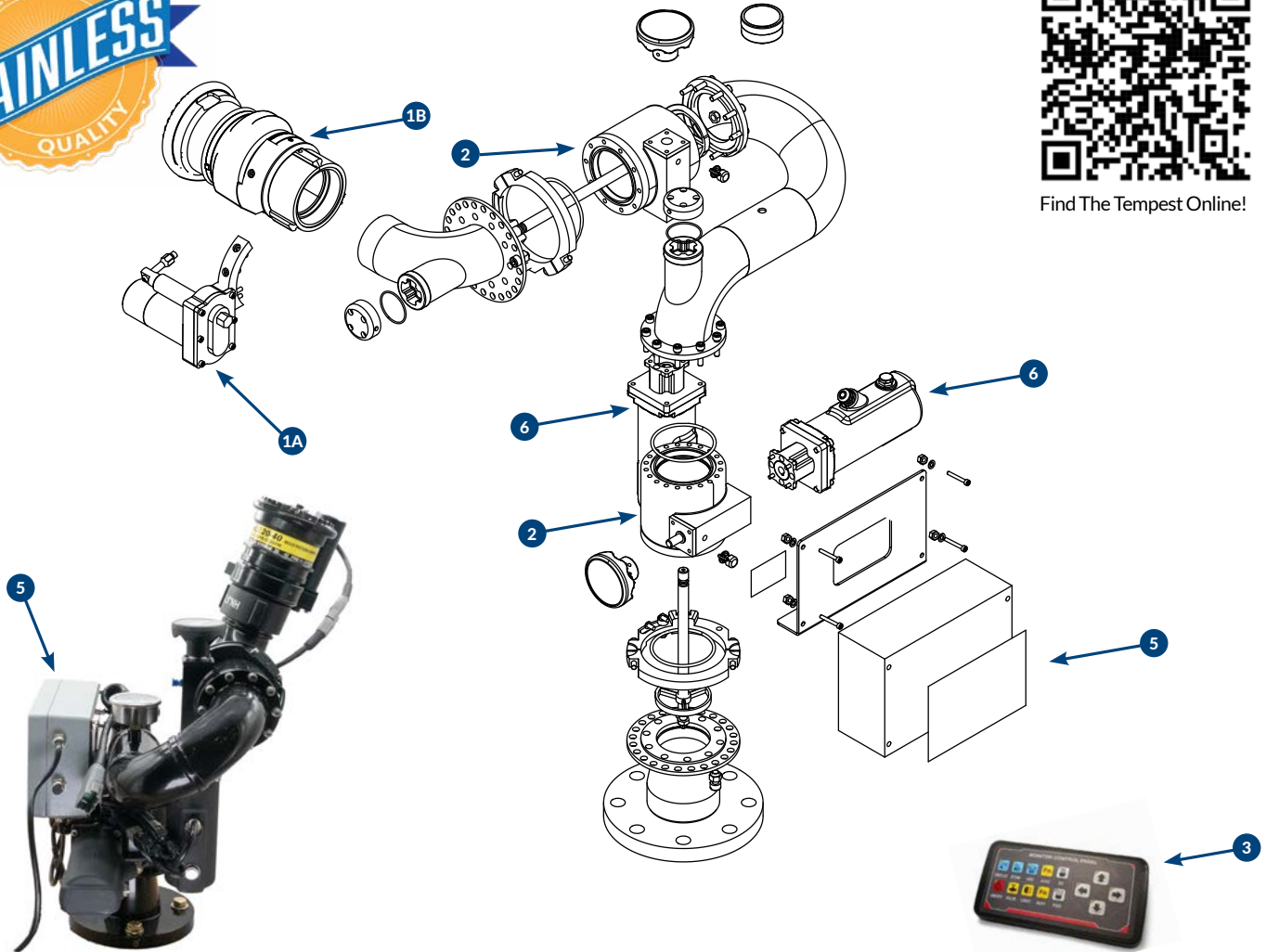

Remote Control



Joystick

TEMPEST CONTROL VALVE (OPTIONAL)
Air-to-Open / Spring Return



TYPE	SKU
3"	173B-300-SRE



Optional 24V to 12V transformer available

ALL INCLUSIVE KIT

- ✓ CONTROL BOX
- ✓ MONITOR
- ✓ JOYSTICK
- ✓ HARNESS

PARTS CONTINUED ON NEXT PAGE

TEMPEST CANNON UPGRADE & REPLACEMENT PARTS

JET SPRAY NOZZLE

1



TYPE	SKU
1A Nozzle Motor	2881-W3004009
1B Nozzle Only	2881-S204502101
Nozzle & Motor	2881-PTZCDP2040A

MONITOR SWIVEL ASSEMBLY

2



TYPE	SKU
Replacement Swivel	2881-S204802301

MONITOR REMOTE CONTROL

3



TYPE	SKU
Remote Control	2881-WP1-3

24 VOLT TRANSFORMER

4



TYPE	SKU
24V	2881-DCP24/12

MONITOR CONTROL BOX

5



TYPE	SKU
Control Box w/ Leads	2881-NCU-09

MONITOR MOTOR ASSEMBLY

6



TYPE	SKU
12V	2881-S204802401

JOYSTICK MONITOR CABLE

7



TYPE	SKU
40'	2881-CTRL-CB01

MONITOR JOYSTICK

8



TYPE	SKU
One Size	2881-CTRL-J01

The new Tempest is equipped with more powerful motors and an entirely updated control system. Our control boxes and cables have been reduced and integrated onto the cannon itself to improve space efficiency and ease of installation.

Find all of The Tempest Water Cannon upgrades, addons, and replacement parts on our website
AccessTruckParts.ca/tempest

TANK HARDWARE

DRESSER PIPE COUPLING



TYPE	SKU
3"	255-300
4"	255-400

TANK SPRING



TYPE	SKU
Standard	SPRING-WTRTK

HYDRAULICS

HYDRAULIC MOTORS

M20, MK20, M50, MK50, M75



TYPE	SKU
Please call for more info and pricing.	

U-JOINTS



TYPE	SKU
1000 Series U-Joint	345-1000
1310 Series U-Joint	345-1310

HYDRAULIC PUMP ADAPTER

Keyed/Splined Coupling Included



TYPE	SKU
B3Z Framed Pumps	115-B07779

1000 SERIES END YOKE



TYPE	SKU
1-1/4" x 5/16" Key	343-1025
1-1/8" x 1/4" Key	343-1125
7/8" x 13 Tooth Spline	343-0875SP

HYDRAULIC COUPLING

B3Z/B3J, B4J



TYPE	SKU
1-1/4" 14 Tooth Splined	116-M10176

1310 SERIES END YOKE



TYPE	SKU
1-1/8" x 1/4" Key	344-1125
1-1/4" x 5/16" Key	344-1025
1-1/2" x 3/8" Key	344-1050

BRUSH HAWK ELECTRIC WATER CANNON

12V/24V ELKHART BRUSH HAWK CANNON
Aluminum construction, CANbus enabled



Monitor only.



All components sold separately.

TYPE	SKU
2" x 1½" Waterway Brush Hawk Cannon	2841-08495002

12V/24V BRUSH HAWK JOYSTICK
Used with Brush Hawk Cannon



TYPE	SKU
12/24 Volt Brush Hawk Joystick	2841-81899000

BRUSH HAWK WIRING HARNESS
Used with Brush Hawk Cannon



2841-37543002



2841-37543030

TYPE	SKU
12/24 Volt Brush Hawk Harness - 2'	2841-37543002
12/24 Volt Brush Hawk Harness - 20'	2841-37543020
12/24 Volt Brush Hawk Harness - 30'	2841-37543030

12V/24V ELECTRIC BALL VALVE
Used with Brush Hawk Cannon



TYPE	SKU
12/24 Volt Ball Valve	2841-70213001

12V/24V ADJUSTABLE NOZZLE
Used with Brush Hawk Cannon



350GPM

TYPE	SKU
12/24 Volt Adjustable Nozzle	2841-05000058

NITRO ELECTRIC WATER CANNON

12V/24V ELKHART NITRO CANNON
Monitor, Joystick, Harness & Control Box



Standard nozzle: 500GPM

TYPE	SKU
2½" x 2½" Waterway Nitro Cannon Kit	286-8100

NITRO CANNON ADJUSTABLE NOZZLE
Variable Stream from Fog to Straight



500GPM

TYPE	SKU
12/24 Volt Adjustable Nozzle	2861-7000803

NITRO CANNON JOYSTICK
Included with Cannon



TYPE	SKU
12/24 Volt Nitro Joystick	2861-41067000

CANNON NOZZLES

STRAIGHT STREAM NOZZLES
Brass and Aluminum



TYPE	SKU
1½" Aluminum Straight Stream	2831-66761007
1½" Brass Straight Stream	311-150
2½" Brass Straight Stream	311-250

MANUAL CANNONS

ELKHART MANUAL CANNON
Aluminum Construction, Threaded



Shown with optional 1-1/2" Straight Stream Nozzle

TYPE	SKU
2x1½" Waterway Manual Cannon	283-8492
1½" Brass Straight Stream	311-150
2½" Brass Straight Stream	311-250

PS20-40 MANUAL CANNON
Aluminum Construction, Flanged



Adjustable nozzle included

TYPE	SKU
3" Flange x 2-1/2" Waterway	281-PS20-40W-C
1½" Brass Straight Stream	311-150
2½" Brass Straight Stream	311-250

STANDARD PLUMBING LAYOUT

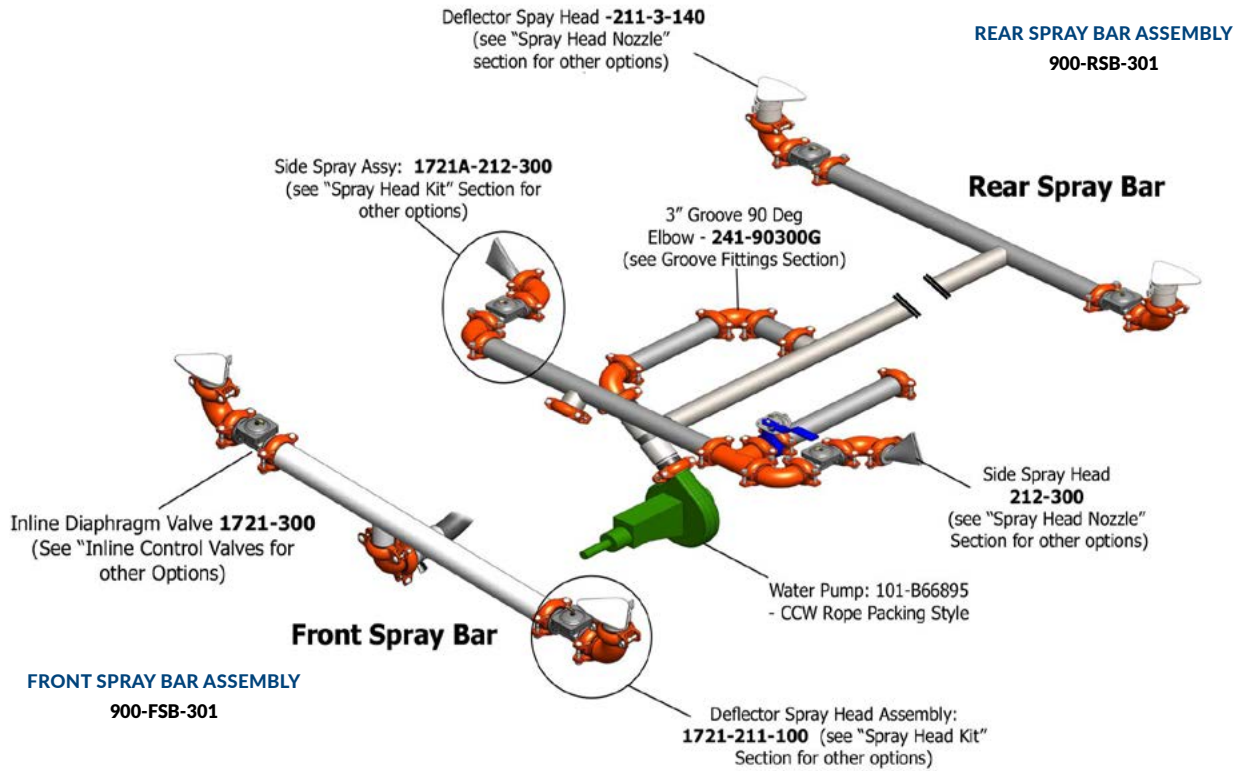

FRONT SPRAY BAR ASSEMBLY

This Front Spray Bar Assembly comes with everything you need to add an entire spray bar to the front of your Water Truck. Includes grooved pipe, couplings, elbows, deflector spray heads, inline control valves, front bumper mounts and air fittings/tubes.

REAR SPRAY BAR ASSEMBLY

This Rear Spray Bar Assembly comes with everything you need to add an entire spray bar to the back of your Water Truck. Includes grooved pipe, couplings, elbows, deflector spray heads, inline control valves and air fittings/tubes.

FRONT SPRAY BAR
900-FSB-301

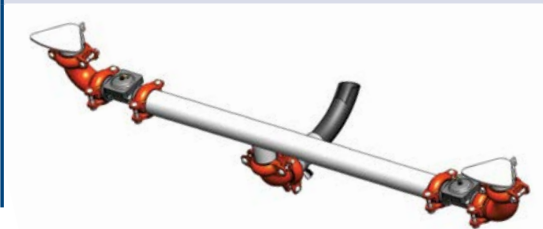

TYPE	SKU
60" Groove Pipe	2410-3x60.000
GROOVE X NOTCH NIPPLE	249-300
3" INLINE GROOVE VALVE	1721-300
3" DEFLECTOR FAN SPRAY HEAD (SHORT)	211-3-100
3" 90° GROOVE ELBOW	241-90300
3" x 2.5" Reducing Coupling	251-300x250
2.5" Groove x Hose Barb Nipple	244-250
Front Bumper Mount	900-FRONTBRKT
3" Zero Flex Groove Coupling	251-300ZFG
1/4 x 1/8 Male Elbow Air Fitting	32604-NE90M25P125S
Black 1/4 Air Tubing	32608-PU4BLK
3" Galvanized	245-300-G

REAR SPRAY BAR
900-RSB-301

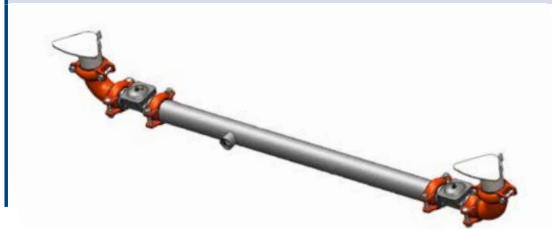

TYPE	SKU
60" Groove Pipe	2410-3x60.000
GROOVE X NOTCH NIPPLE	249-300
3" INLINE GROOVE VALVE	1721-300
3" DEFLECTOR FAN SPRAY HEAD (SHORT)	211-3-100
3" 90° GROOVE ELBOW	241-90300
1/4 X 1/8 Male Elbow Air Fitting	32604-NE90M25P125S
Black 1/4 Air Tubing	32608-PU4BLK
3' Zero Flex Groove Coupling	251-300ZFG

SUCTION LOADING (CREEK FILL)

Non Self-Priming Pumps

- To sufficiently flood the pump volute and fill hose before operation, there must be enough water left in the tank. When this is not the case, water can be drawn into the pump with the installation of a hand primer.

SUCTION LIFT WITH HAND PRIMER PUMP

- Close air tight valve on discharge of Primer.
- Open hand primer isolation valve. Work handle of hand primer up and down to evacuate air from the suction line.
- When water flows freely from primer, close Hand Primer isolation valve. (Pump case should now be filled with water). Proceed to normal loading procedure.

Protek
Primer



DP5: 327-DP5

ATP
Primer



327-ATP7

Guzzler
Primer



327-GH0400

- Connect fill hose to cam-lock fitting (10) on suction plumbing and lower Foot Valve into water source.
- Close 4" butterfly valve (8) between tank supply and suction side of pump. Open the butterfly valve (7) between pump and fill hose and open the butterfly valve (7) between discharge side of pump and return to tank.
- Engage pump and operate at 2000 RPM. If pump isn't moving water at this point, while the pump is engaged:
 - » Simultaneously close the valve between pump hose (7) and open 4" tank supply valve (8), creating a flow of water through the pump.
 - » Next, reverse these valves at the same time and the resulting momentum of flow through the pump should start filling the tank.
- If system STILL won't prime, check the valve positioning, check for obstructions behind the pump, check if the pump shaft is broken, ensure ALL hose connections are air tight and that the foot valve or strainer is not blocked or obstructed.

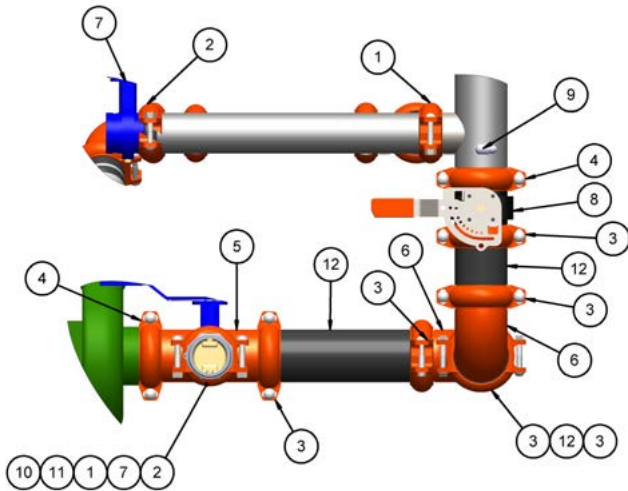

Side View

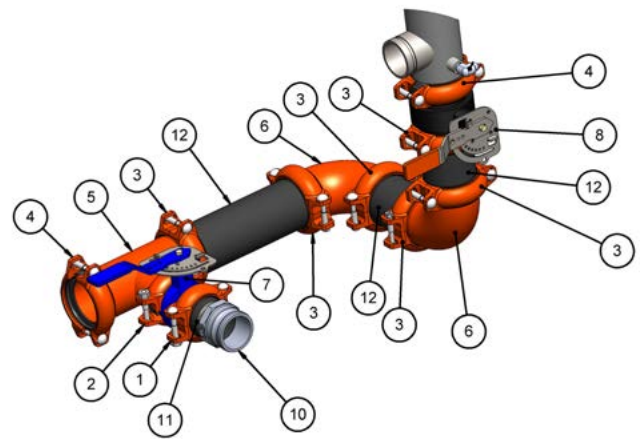

Top View

ITEM#:	QTY	PART#	DESCRIPTION
1-12		900-SP300	SUCTION PLUMBING KIT
1	2	251-300FG	3" Flexible Groove Clamp
2	2	251-300ZFG	3" Angle Pad Groove Clamp
3	6	251-400FG	4" Flexible Groove Clamp
4	2	251-400ZFG	4" Angle Pad Groove Clamp
5	1	243-400x300-G	4" x 4" x 3" Reducing Groove Tee

ITEM#:	QTY	PART#	DESCRIPTION
6	2	241-90400-G	4" 90 Deg Groove Elbow
7	2	182-300	3" Groove Butterfly Valve
8	1	182-400	4" Groove Butterfly Valve
10	1	262-300A	3" MCAM x FMPT
11	1	245-300	3" Groove x 3" MPT Nipple
12	1	-	Extension Pipe, Length will Vary

AIR CONTROL PANELS

OPEN CONTROL PANEL

Painted Steel, Adjustable Height

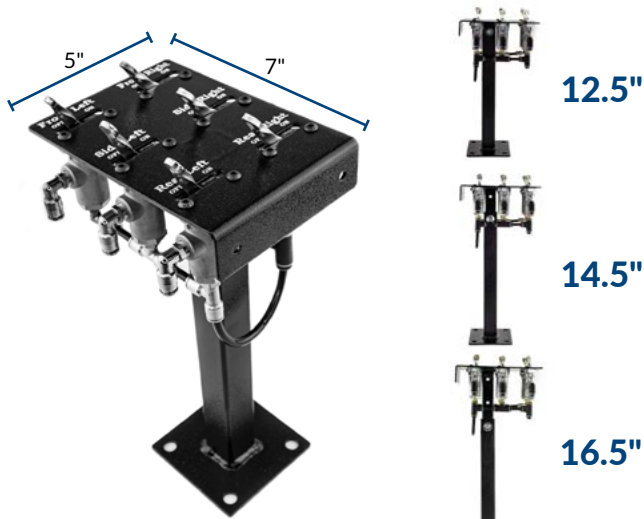

TYPE	SKU
2 Switch	325-2
3 Switch	325-3
4 Switch	325-4
5 Switch	325-5
6 Switch	325-6
8 Switch	325-8

ENCLOSED CONTROL PANEL

Painted Steel

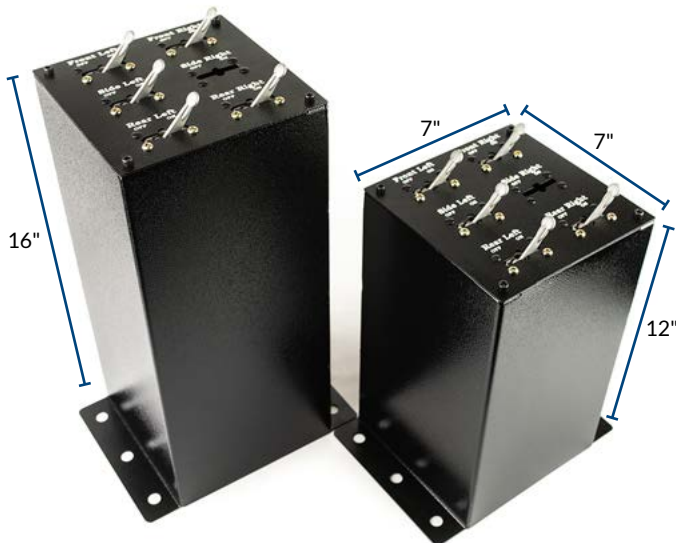

TYPE	SKU
12" Tall 5 Switch Panel	325-101200-5-12
16" Tall 5 Switch Panel	325-101200-5-16
12" Tall 6 Switch Panel	325-101200-6-12
16" Tall 6 Switch Panel	325-101200-6-16

CONTROL SWITCHES

ASSORTED TYPES

Air and Electric



TYPE	SKU
A Toggle Switch	331-6451000
B MJTV3 Air Toggle	331-MJTV3
C MJTV4 Air Toggle	331-MJTV4
D Valve Switch (Valew)	331-S3YO6T
E AGM (Electric)	331-AGM
F 2-Way, Push Pull	331-BAV10
G 2-Way, Control Valve	331-18HL4

MANUAL CONTROLS & CABLES

CONTROL CABLES

Push-Pull Type

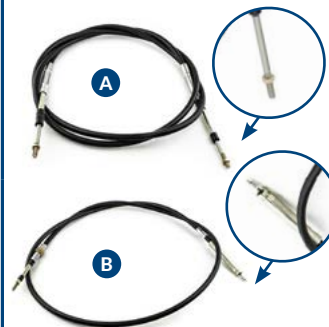

TYPE	SKU
A 1/4" x 84"	323-5203BBU084
A 1/4" x 96"	323-5203BBU096
A 5/16" x 72"	323-6203BBU072
A 5/16" x 84"	323-6203BBU084
A 5/16" x 96"	323-6203BBU096
A 5/16" x 108"	323-6203BBU108
A 5/16" x 120"	323-6203BBU120
B 108"	323-62RVB

CABLE CLEVIS



TYPE	SKU
1/4" Clevis Kit	3231-B27082AZKT
5/16" Clevis Kit	3231-B27083AZKT
Valve Clevis, 5/16" Cable	3231-B27086A56ZY

CONTROL LEVER

Heavy Duty



TYPE	SKU
For 1/4" Cable	323-HDCL352
For 5/16" Cable	323-HDCL362

REMOTE CONTROL LEVER

Used With 62RBV Cable



TYPE	SKU
Left Hand	323-FA-08-5917-01-SH
Right Hand	323-FA-08-5917-02-SH
Middle	323-PTK0003MIDRVC SH

AIR HOSE FITTINGS

DOT Approved



TYPE	DESCRIPTION	SKU	
A	Male Swivel Elbow	1/4" Hose x 1/8" MPT	32604-NE90M25P125S
	Male Swivel Elbow	1/4" Hose x 1/4" MPT	32604-NE90M25P25S
	Male Swivel Elbow	6mm Hose x 1/4" Thread	32604ME-6mmx4
B	Male Run Tee	1/4" Hose x 1/8" MPT	32602-NRT0M25P125S
C	Male Branch Tee	1/4" Hose x 1/8" MPT	32601-NBT0M25P125S
D	Male Connector	1/4" Hose x 1/8" MPT	32603-NC00M25P125
	Male Connector	1/4" Hose x 1/4" MPT	32603-NC00M25P25
E	Straight Union	1/4" Hose x 1/4" Hose	32605SU-025

QUICK EXHAUST VALVES



DESCRIPTION	SKU
A 1/8" Quick Exhaust Valve	1911-QEV-125
A 1/4" Quick Exhaust Valve	1911-QEV-025
B 1/4" Quick Exhaust Valve	1911-QEV-3800
C 1/8" NPT Straight Quick Exhaust	1911-QEV-STR

AIR CYLINDERS

2" & 3" BORE
Clevis and Pivot Mounted



TYPE	SKU
2" BORE	
2" Stroke	321-2x2
4" Stroke	321-2x4
6" Stroke	321-2x6
3" BORE	
6" Stroke	321-3x6
8" Stroke	321-3x8
10" Stroke	321-3x10

CYLINDER CLEVIS



CYLINDER TYPE	SKU
2" Rod Clevis	3211-D-231-3
3" Rod Clevis	3211-8314A

CYLINDER PIVOT



CYLINDER TYPE	SKU
2" Cylinder Pivot	3211-D-620
3" Cylinder Pivot	3211-D-13512-A

MISC FITTINGS

AIR REGULATOR



TYPE	SKU
1/4"	162-110147

PRESSURE PROTECTION VALVE



TYPE	SKU
1/4"	333-6451005

STRAINER FITTINGS

For Solenoid Valves



TYPE	SKU
A Tee Jet Adaptor, 1/4"	32615-4676-1/4
B Tee Jet Strainer w/ SS Screen	32615-5053
C Tee Jet Body, 1/4"	32615-CP1322

AIR TUBING

By the Foot, Other Colors Available



TYPE	SKU
1/4"	32608-PU4BLK

PETCOCK



TYPE	SKU
1/4"	32617-PETCOCK

HEX NIPPLES



TYPE	SKU
1/8" x 1/8" Nipple	326070202
1/4" x 1/8" Reducing Nipple	326070402
1/4" x 1/4" Nipple	326070404

PIPE PLUGS



TYPE	SKU
1/8"	32609-125
1/4"	32609-025

TANK SITE GAUGE

For Viewing Tank Water Level



TYPE	SKU
A 5/8" (OD) Tubing - Per Foot	32608-SITETUBE
B 5/8" x 1/2" Site Gauge Fitting w/ Ferrule	32616-TANKFIT
C 5/8" Site Gauge Fitting Insert	32616-2030x10

Hose

Other Hose Sizes Available Upon Request

WATER HOSE For Hose Reels



TYPE	SKU
1" x 50'	301-100x50
1" x 100'	301-100x100
1½" x 50'	301-150x50A

DOUBLE JACKET MILL HOSE For Filling



TYPE	SKU
2" x 50'-400psi	304-200x50
2½" x 25'-400psi	304-250x25
2½" x 50'-400psi	304-250x50

DOUBLE JACKET MILL HOSE For Jetting



TYPE	SKU
1½" x 50'-300psi	308-150x50
2½" x 50'-300psi	308-250x50
1½" x 50' HD-800psi	308-150x50HD

SUCTION HOSE For Suction Loading



TYPE	SKU
3" x 15'	303-300x15
3" x 25'	303-300x25

Nozzles

STRAIGHT STREAM Brass



TYPE	THREAD	SKU
1½"	NH/NST	311-150
2½"	NH/NST	311-250

JET NOZZLES Brass



TYPE	SKU
¾"	313-075x250
¾"	313-075x400
¾"	313-050x400
¾"	313-075

FOG NOZZLE Brass, Adjustable



TYPE	THREAD	SKU
1"	NPSH	312-100BR
1½"	NPSH	312-150BR
2½"	NPSH	312-250BR

FOG NOZZLE Plastic, Adjustable



TYPE	THREAD	SKU
1"	NPSH	312-100
1½"	NPSH	312-150
2"	NPSH	312-200
1"	NST	312-1.0NST

Hose Clamps

DIXON DOUBLE BOLT Sized by Hose Outer Diameter



TYPE	SKU
¾" to 1 3/16"	305-D400
350/64" to 41/16"	305-D431
4¼" to 415/16"	305-D525
51/8" to 511/16"	305-D600

T-BOLT CLAMP Sized by Hose Outer Diameter



TYPE	SKU
1.34" to 1.56"	305-150
1.84" to 2.06"	305-200
2.34" to 2.56"	305-250
2.76" to 3.06"	305-300
3.24" to 3.51"	305-350
4.23" to 4.52"	305-450

Strainer / Foot Valve

FOOT VALVE Painted Malleable Iron



TYPE	SKU
3"	305-FTV300
Repair Kit	3051-FTVKIT

SUCTION STRAINER Stainless Steel



TYPE	SKU
3"	305-STR300

Hand Primers

PROTEK HAND PRIMER Aluminum Body, Rubber Diaphragm



TYPE	SKU
DP5 Primer	327-DP5
DP5 Diaphragm	3271-DP5

GUZZLER HAND PRIMER Delrin Body, Buna Diaphragm



TYPE	SKU
Guzzler Primer	327-GH0400
Repair Kit	3271-SK-N4NOX-11

Hydrant Tools

HYDRANT ADAPTOR Brass



TYPE	THREAD	SKU
2½"	FNST×MNPT	306-ADAPT
2½"	FPHX×MNPT	306-PHX

HYDRANT WRENCH Steel



TYPE	SKU
Adjustable	306-WRENCH

HOSE REEL KITS



TYPE	1" x 50' SKU	1½" x 50' SKU	QTY
HOSE REEL KIT	291-1175-6-50-KIT	291-1185-1124-KIT	1 KIT
A Manual Hose Reel	291-1175-6-50	291-1185-1124	1
B Water Hose	301-100x50	301-150x50A	1
C Jumper Hose	301-HOSE100	301-HOSE150	1
D 90° Street Elbow	90° Swivel Included	233-90150	1
E Ball Valve	183-100	183-150	1
F Thread x Weld Nipple	239-100	239-150	1
G Thread x Hose Barb Nipple	238-100	238-150	2
H Dixon T-Bolt Clamp	305-150	305-200	4
I Plastic Fog Nozzle	312-100	312-150	1



TYPE	SKU	QTY
1½" HOSE REEL KIT	292-1185-1124-ASM-KIT-SVL	1 KIT
A 1½" Manual Hose Reel	292-1185-1124-ASM-SVL	1
B 1½" Water Hose 50'	301-150x50A	1
C 1½" Jumper Hose	301-HOSE150	1
D 1½" Ball Valve	183-150	1
E 1½" Thread x Weld Nipple	239-150	1
F 1½" Thread x Hose Barb Nipple	238-150	2
G 1½" T-Bolt Clamp	305-200	4
H 1½" Plastic Fog Nozzle	312-150	1
I 304SS Full-Flow NPT Swivel	294-8970-SVL	1

COXREELS MANUAL REWIND HOSE REELS

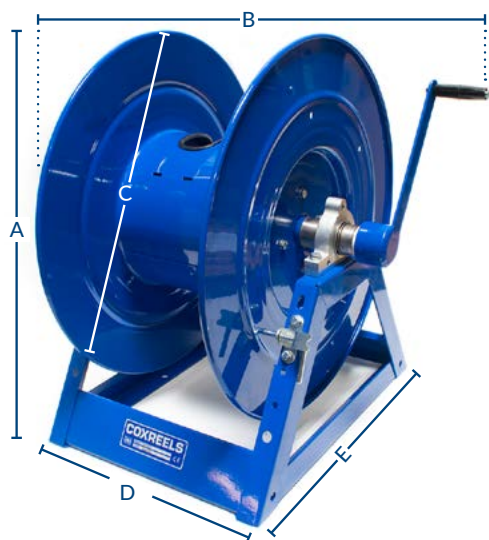

PART#:	HOSE SIZE	(A)	(B)	(C)	(D)	(E)	(LBS.)
291-1175-6-50	1" x 50'	26-1/4"	24-3/4"	24"	12-7/8"	20-1/8"	67
291-1185-1124	1-1/2" x 50'	25"	24-1/8"	24"	17-1/16"	22-3/16"	76
291-1185-2024	1-1/2" x 100'	25"	34-11/16"	24"	24-1/16"	22-3/16"	94

HOSE REEL PARTS



TYPE	SKU
A 1½" Hose Reel Swivel (Rev D)	294-8970
B 1½" Reel Outer Swivel Plate (Rev D)	294-8956
C Bearing Assembly (Rev D)	294-8954
D Washer Bearing	294-8960
E Retaining Ring	294-20252
F Swivel O-Ring Kit	294-8970-KIT
G Axle Assembly (Rev D)	294-8962-1150
H Reel Locking Pin	294-20843
I Crank Assembly	294-8191

CLOCKWISE (CW)

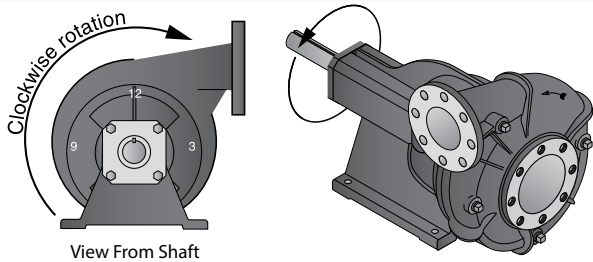

COUNTER-CLOCKWISE (CCW)

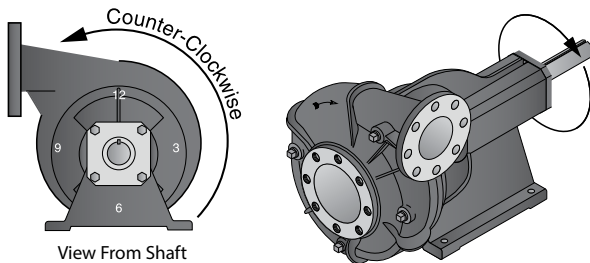

CHECK PUMP ROTATION:

Centrifugal pumps come in Clockwise (CW) and Counterclockwise (CCW) configurations. CW pumps are used with automatic transmissions, while CCW pumps are used with manual transmissions. A pump running in the wrong direction will still pump liquids, however GPM and head will be a fraction of the published performance. Before a pump is put into operation, rotational direction must be checked to ensure proper performance of pump. Refer to illustration above.

LUBRICATION:

» **IMPORTANT:** Grease should be added to the bearing frame as required by daily and weekly routine inspections. Add only enough of a lithium-based NGLI No. 2 extra pressure ball bearing grease to coat each bearing, excess grease will cause bearings to run hot. Never run a pump without water, doing so will cause overheating and damage to internal parts. The liquid end of the pump requires no lubrication. Wear rings, packing rings, and models using a mechanical shaft seal are lubricated and cooled by the liquid being pumped.

STARTING A NEW MECHANICAL SEAL PUMP:

Adjustment or maintenance of a mechanical seal is normally not required. The seal is enclosed within the

WATER TRUCK PUMP SELECTOR:

Choosing which water truck pump you need can be a complicated process. We want to make it EASY. Scan here and we will help you to find out which of our pumps will work for you.



pump and is self-adjusting. Seal is cooled and lubricated by the liquid being pumped.

STARTING A NEW ROPE SEAL PUMP:

Loosen rope packing gland nuts and re-tighten finger tight. Once running, allow packing to leak liberally for a few moments, then tighten gland nuts one complete turn each until leakage is reduced to 40 to 60 drops per minute. Over-tightening of packing will cause damage to shaft and promote further leakage.

USING CABLE OR AIR SHIFT PTO:

» **IMPORTANT:** To avoid Transmission or PTO damage, only engage the PTO while the truck is standing still, NEVER while moving. DO NOT close spray heads under full pressure! Let the engine wind down with clutch disengaged before closing the spray head valves to avoid pump or spray head damage.

ROUTINE MAINTENANCE:

A well maintained pumping system will extend the life of the unit and require fewer repairs. This means less down time which can be very critical when a constant delivery of water is required. A routine maintenance and inspection schedule should be set up on a weekly, quarterly, and annual basis with records kept of these actions.

WEEKLY:

- **Vibration** – If excessive vibration is present, discontinue use to determine the cause and correct.
- **Noise** – Listen closely for unusual sounds that might indicate the unit is in distress.
- **Operating Temperature** – The surface of the pump bracket may reach temperatures as high as 150°F which is normal. If the surface temperature of the pump or driver is excessive, discontinue operation. Bearings will run hotter for a brief run-in period after packing which is normal, however worn bearings will cause excessive temperatures and need to be replaced.
- **Rope Seal** – After a short period of operation, verify that the rope packing box and gland are not hot. If heat is detected, loosen the gland nuts evenly until water begins to drip from the packing box. Water must not be streaming or spraying out. Verify cool operation periodically. Adjust gland nuts **EVENLY** as necessary until 40-60 drops per minute is achieved. If packing has been tightened to the limit of the packing gland travel, additional packing may be necessary.
- **Mechanical Seal** – There should be no leakage from a mechanical seal, if there is it needs to be replaced.

QUARTERLY:

- **Inspect Pump and Piping Connections** – Check all system piping connections for leakage. Verify there is no pipe misalignment to the pump which will put excessive strain on the volute and can cause damage to internal components of both the pump and motor. Adjust pipe supports as needed to correct.
- **Flange Connections** – For flange connections, misalignment can be checked by shutting down the pump and removing the pipe flange bolts on the pump connections. If the mating flanges come apart or shift, there is pressure at the connection and adjustments should be made to the piping supports until flanges mate directly without force. This procedure can be done throughout the piping system.
- **Check Pump Foundation Integrity** – Ensure the foundation is intact and all hold-down bolts are secure.
- **Lubricate Bearings** – Check for adequate lubrication of all bearings and add as needed.

- **Check Seals** – Inspect packing or mechanical seal for possible replacement. Examine shaft sleeve if present for wear and replace if necessary.
- **Inspect Pumping Plant** – Look for signs of wear and replace/repair worn parts as necessary.
- **Check Bearings** – Repack, grease or replace as necessary.

ANNUALLY:

- **Check Bearings** – Repack, grease or replace as necessary.
- **Inspect Internal Parts** – Look for signs of wear on all valves, screens, gaskets, diaphragms etc. Inspect impeller condition, eye clearance, volute case and seal chamber for signs of excessive wear or corrosion.

WINTERIZING:

The following storage procedures should be observed when a pump will be out of service for more than a month.

- **Clean** – Remove exterior dirt, grime or any substance that may trap moisture. Prime exposed metal and repaint if necessary.
- **Flush** – Flush suction and discharge lines. Check for leaks at this time and replace any worn gaskets.
- **Lubricate** – All bearings and seals.
- **Dry** – Dry the pump and if possible, keep unit clean and dry during storage period to guard against corrosion.
- **Seal** – Seal all open ports to keep out foreign objects such as insects, rodents, dust and dirt.
- **Shelter** – Shelter pump from the elements when possible.
- **Rotate** – Turn the driver shaft periodically to prevent freeze-up of internal components.

PUMP PERFORMANCE CURVES

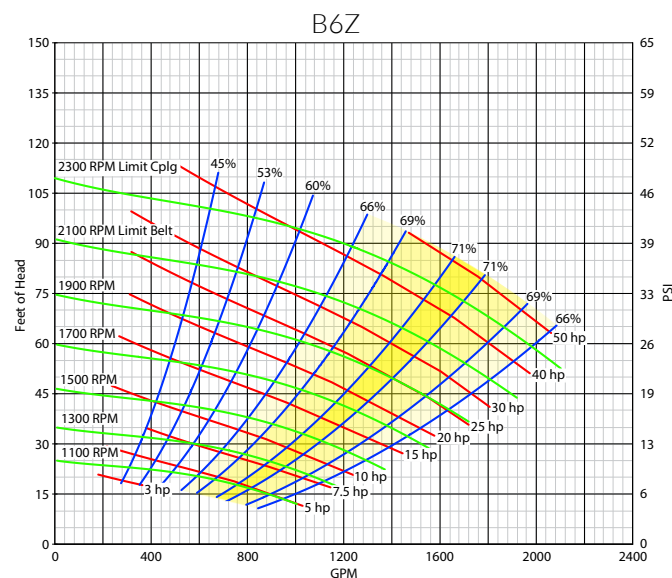
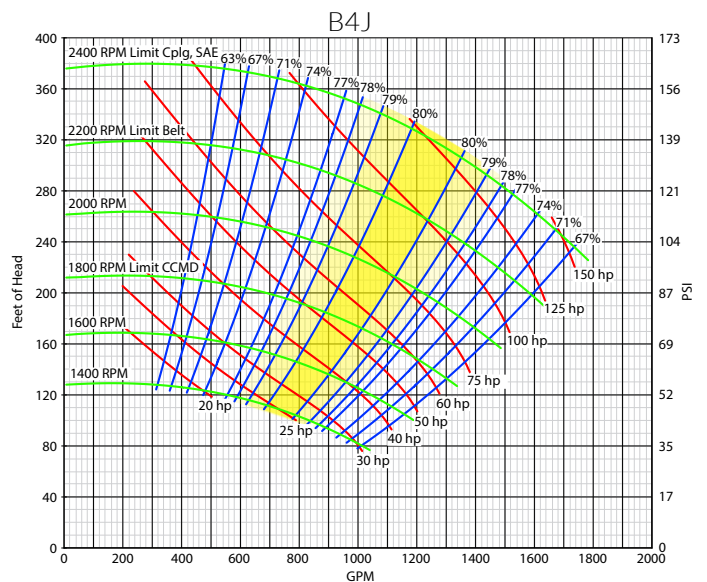
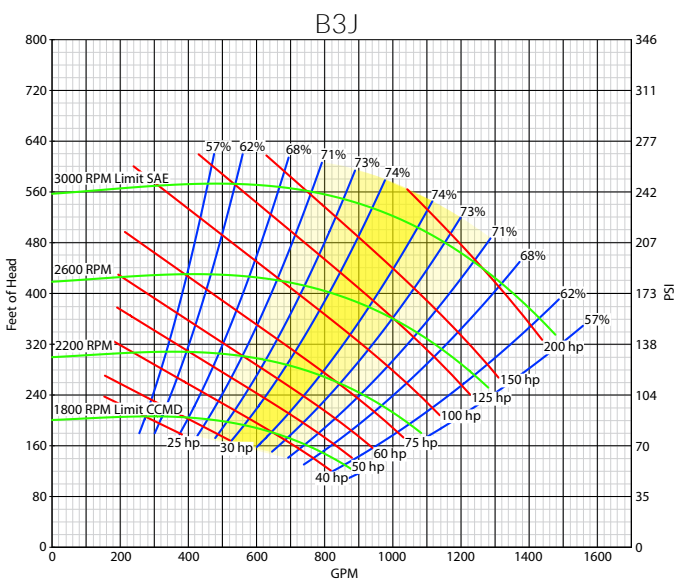
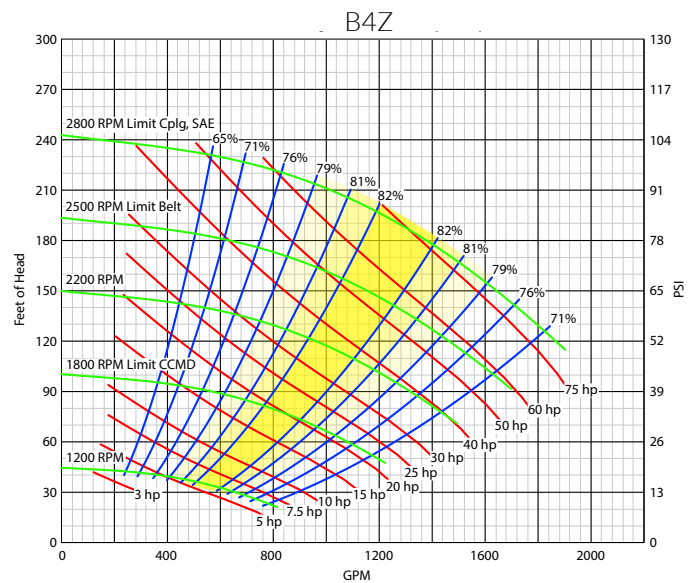
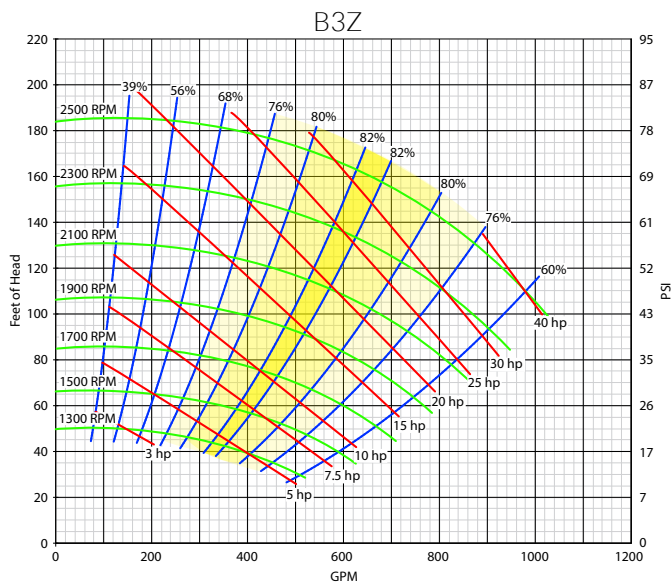

HOW TO READ A PUMP CURVE

These pump performance curves plot flow rate (GPM) on the horizontal plane, pressure (listed in Feet of Head and PSI) on the vertical plane, pump operating efficiency percentage in blue, variable RPM flow rate/pressure curves in green, and the required horsepower in red.

Given operating RPM and horsepower available, the yellow bands on the graph show where the pump operates at maximum efficiency as well as the corresponding PSI and GPM produced at that RPM. The listed horsepower ratings are the minimum required to reach that section of the graph. Anything above the red line should be sufficient, anything below may fall short of the listed performance.

All of these curves are graphed for fresh water only. You can convert Feet of Head into PSI for fresh water by multiplying it by 0.433, or vice-versa by multiplying PSI x 2.31. Other liquids will require multiplying the above numbers by that liquid's Specific Gravity.



WE ARE PROUD TO ANNOUNCE OUR PARTNERSHIP WITH



HIGH PRESSURE HYDRAULICS
PUMPS | CYLINDERS | HIGH FORCE TOOLS

ELECTRIC PUMPS



Two Stage Hydraulic System
2K-10K PSI Electric Pumps
w/ Pressure Relief &
Custom Options.

HAND PUMPS



10K-40K PSI, 21-427 in³
Reservoir Capacity, Lightweight
Aluminum or Steel Hand Pumps
w/ High Flow Options.

AIR OVER HYDRAULIC PUMPS



3K-10K PSI, Portable
Air-Over-Hydraulic Pumps w/
Single or Double Acting
Manifold & Pressure Relief
Valve Options.

5-30 TON BOTTLE JACKS



Up to 7" Stroke Standard
Profile Bottle Jack, Available
In Multiple Stroke Sizes To
Suit Various needs.

TOOLS



4-30 Ton Pullers, 1-25 Ton
Spreaders, 2-10 Ton Toe Jacks,
5-30 Ton Bottle Jacks, 10-20 Ton
Nut Splitters Options.

TORQUE WRENCHES



Square Drive Torque
Wrench, 308-5480 ft-lbs
Torque. Made in the USA!

CUSTOM PUMPS & CYLINDERS



Custom Pumps & Cylinders
Built To Meet Any Dimension
Requirements, Lifting Capacity
& Flow Rates.

MAINTENANCE KITS



This Kit Includes a
Snap-Together Design, Durable
Components, a 10K PSI Pump,
a Portable Case, & Comes in 4 &
10 Ton Capacities.

**ORDER THESE PARTS AND MORE AT
POWERXINTERNATIONAL.COM OR CALL 414-988-6202**



WE ARE PROUD TO ANNOUNCE OUR PARTNERSHIP WITH



QUICK CONNECT COUPLER SET
Flat Face, NPT Thread



TYPE	SKU
1/2"	FF12-08N-SET

QUICK DISCONNECT COUPLER SET
Stainless Steel, NPT



TYPE	SKU
1/2" ISO 7241-B	BSS12-08N-SET

QUICK DISCONNECT COUPLER SET
Wet-Line Wing Nut



TYPE	SKU
1-1/2" NPT	4100-24N-SET

QUICK DISCONNECT COUPLER SET
10,000 PSI High Pressure



TYPE	SKU
3/8" TC-371 FD35	BSS12-08N-SET

HYDRAFORCE SOLENOID VALVE COIL
HydraForce, Metri-Pack 150



TYPE	SKU
12v DC, 10 Series	4303512

MANIFOLD VALVE BODY HOUSING
3-Way, #6 SAE Ports, Size 10



TYPE	SKU
Hydraforce	7024360

HYDRAULIC MULTIPLIER KIT
with Couplers and Switch Box Control



TYPE	SKU
3 Circuit Selector Valve	HM3-08-SBC

SOLENOID VALVE
Selector/Diverter



TYPE	SKU
13 GPM, 12v DC	DV50-08S

MOTOR SPOOL CARTRIDGE VALVE
Proportional Solenoid Operated



TYPE	SKU
4-Way, 3-Position	SP08-47D-0-N-00

DIRECTIONAL CONTROL VALVE
5 Spool, 11 GPM



TYPE	SKU
Monoblock	P40G-5A1

VARIABLE FLOW CONTROL VALVE
Adjustable w/ Relief



TYPE	SKU
0-16 GPM, 1/2" NPT	FCR51-08N

THIRD FUNCTION VALVE KIT
Kubota L2501, L3200, L3301, and L3901



TYPE	SKU
Third Function Valve Kit	TFK2

**ORDER THESE PARTS AND MORE AT
SUMMIT-HYDRAULICS.COM OR CALL 602-806-7173**



ACCESSTRUCKPARTS

2757



**#36, 12204 40TH STREET SE
CALGARY, ALBERTA T2Z 4K6**

877-583-5275

SALES@ACCESSTRUCKPARTS.CA

ACCESSTRUCKPARTS.CA