

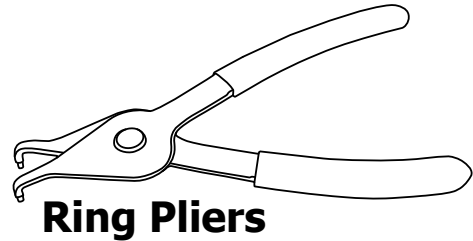

Manual Rewind Hose Reel Assembly Instructions

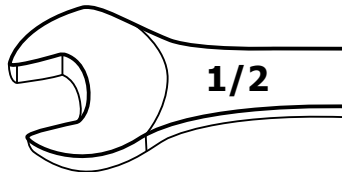

Required Tools

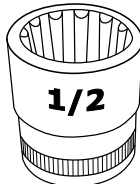
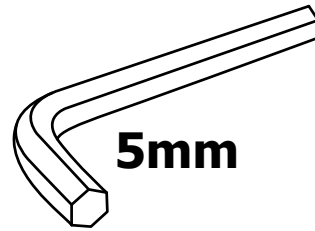
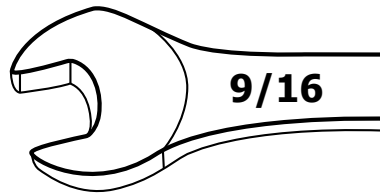

Parts List

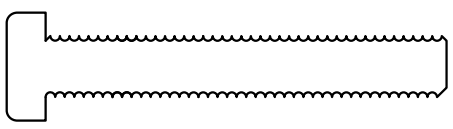
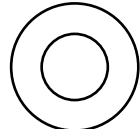
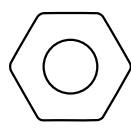
3x	<p>3/8-16 x 2 1/2" Bolt</p> 	14x	<p>3/8" Flat Washer</p> 	7x	<p>3/8" Nut</p> 
----	---	-----	--	----	---

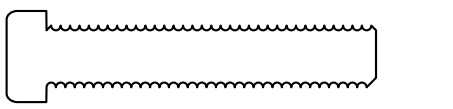
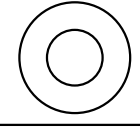
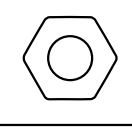
4x	<p>3/8-16 x 2" Bolt</p> 	12x	<p>5/16" Flat Washer</p> 	2x	<p>5/16" Nut</p> 
----	---	-----	---	----	--

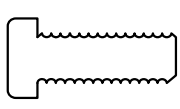
10x	<p>5/16-18 x 7/8" Bolt</p> 	8x	<p>5/16" Lock Washer</p> 
-----	--	----	---

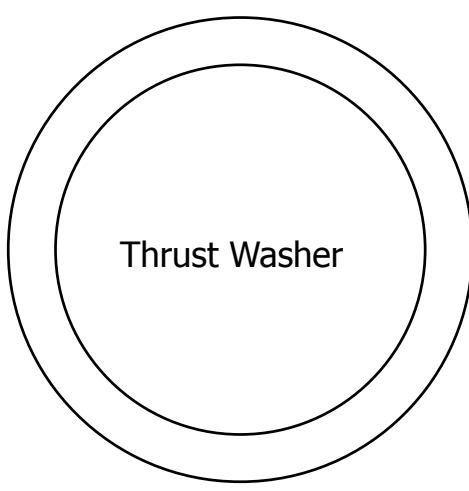
4x	 <p>Thrust Washer</p>
----	--

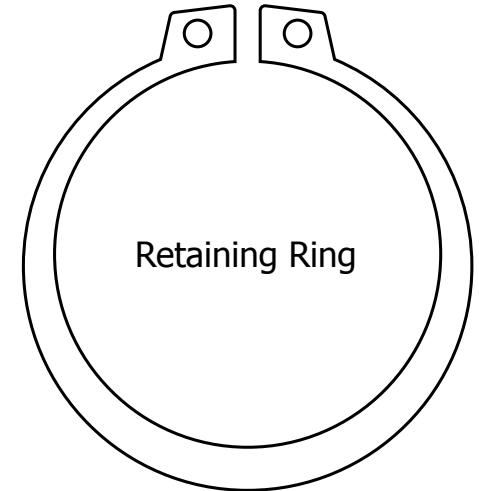
2x	 <p>Retaining Ring</p>
----	--

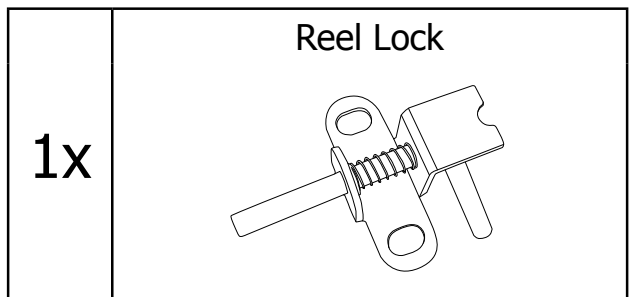
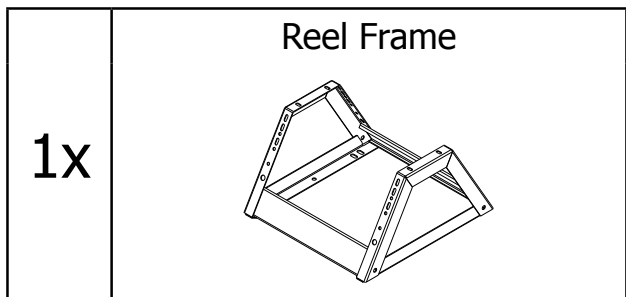
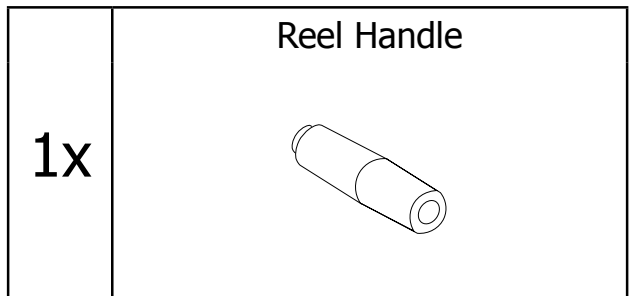
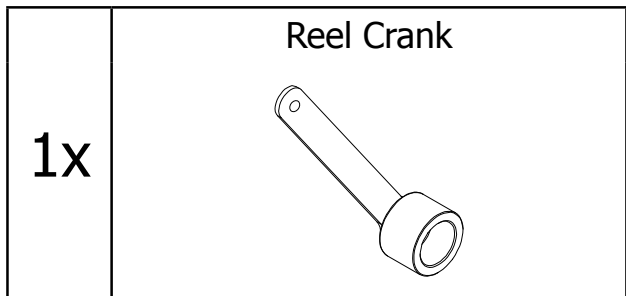
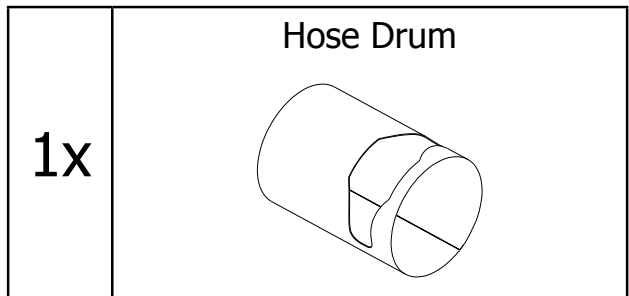
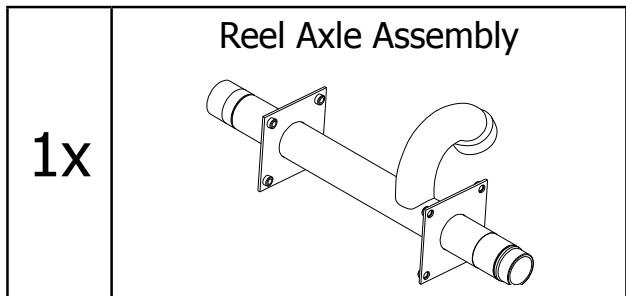
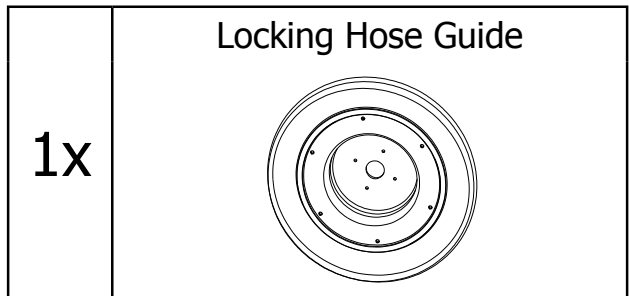
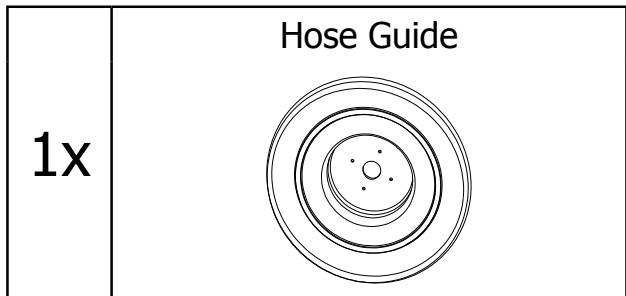
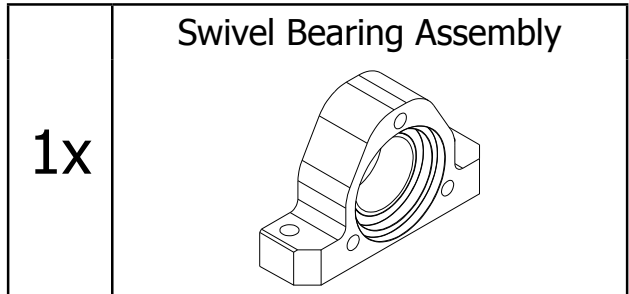
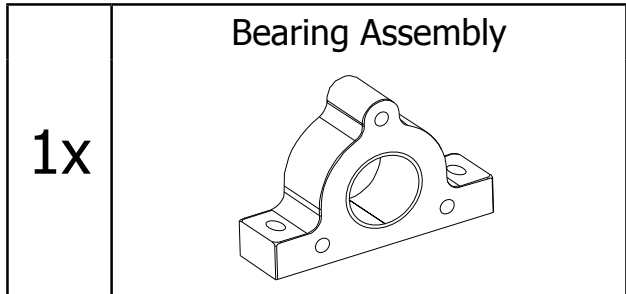
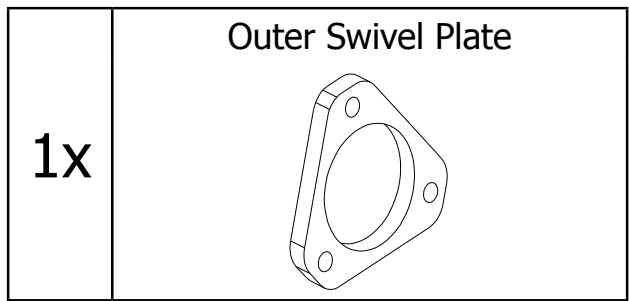
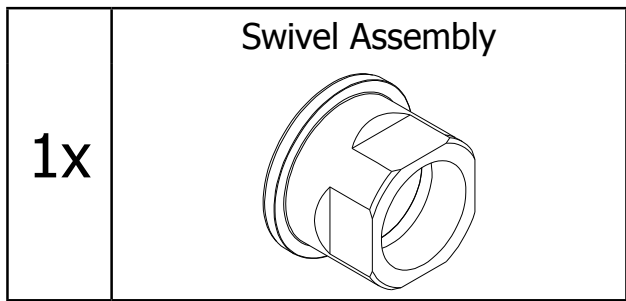

Step 1

Ensure proper orientation of the Hose Mount.

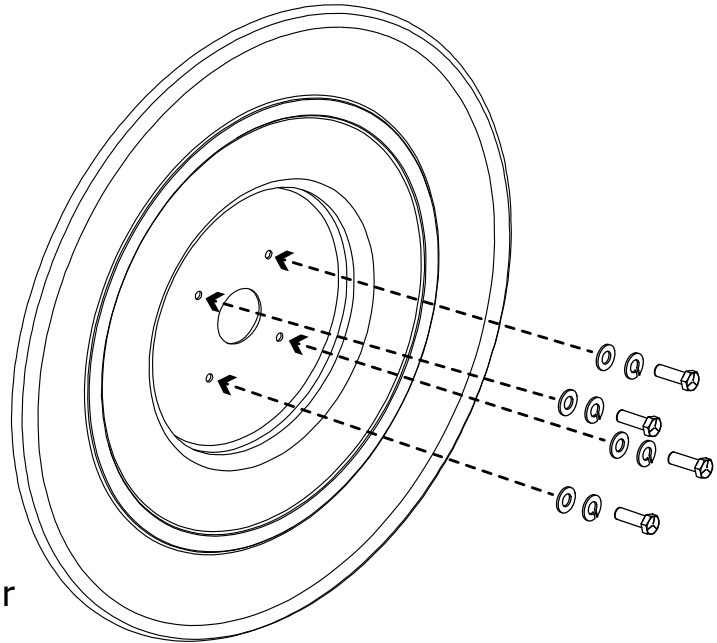
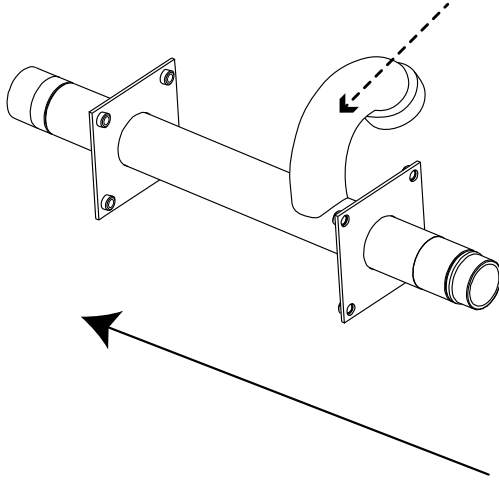

Bolt the Hose Guide without reel lock holes onto the Axle closest to the Hose Mount using four 5/16-18 x 7/8" bolts with four 5/16" locking and flat washers.

Step 2

Locking Hose Guide with reel lock holes must be opposite from the Hose Drum cutout.

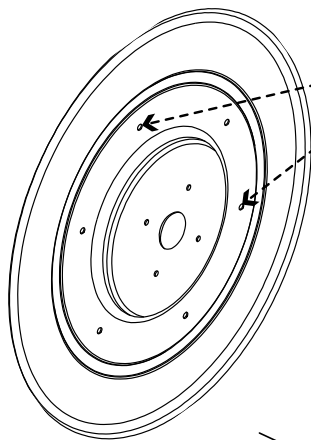
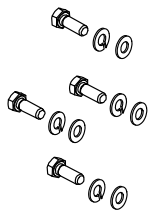

Ensure the Hose Mount is 1/4" from the edge of the Hose Drum cutout.

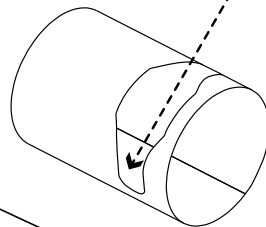

Place Hose Drum over Axle.

Bolt the Locking Hose Guide with reel lock holes onto Axle using four 5/16-18 x 7/8" bolts with four 5/16" locking and flat washers.

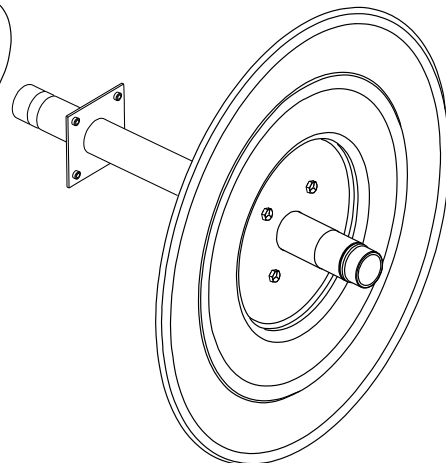

Step 3

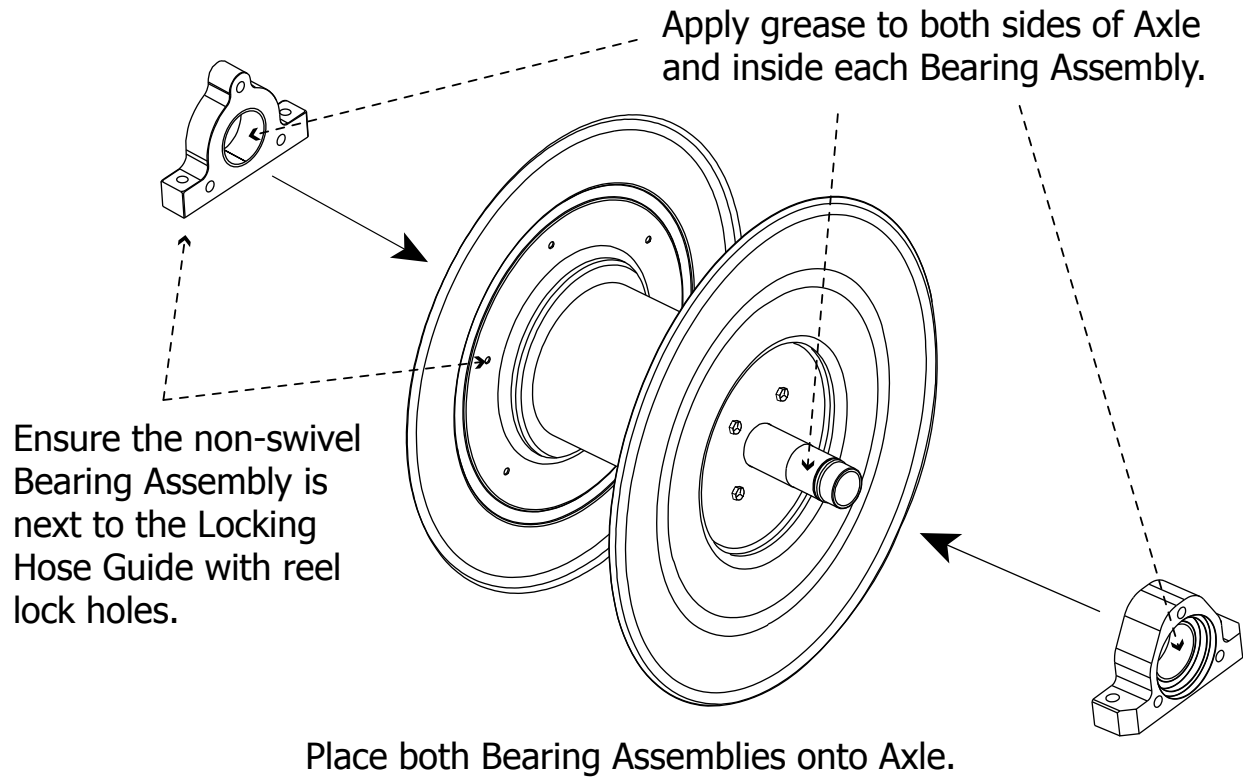

Step 4

Place Reel and both Bearing Assemblies onto Reel Frame.

Bolt each Assembly **loosly** to the Frame using four 3/8-16 x 2" Bolts, eight 3/8" washers and four 3/8" nuts.

The position of the reel will need to be adjusted before final assembly in step 6.

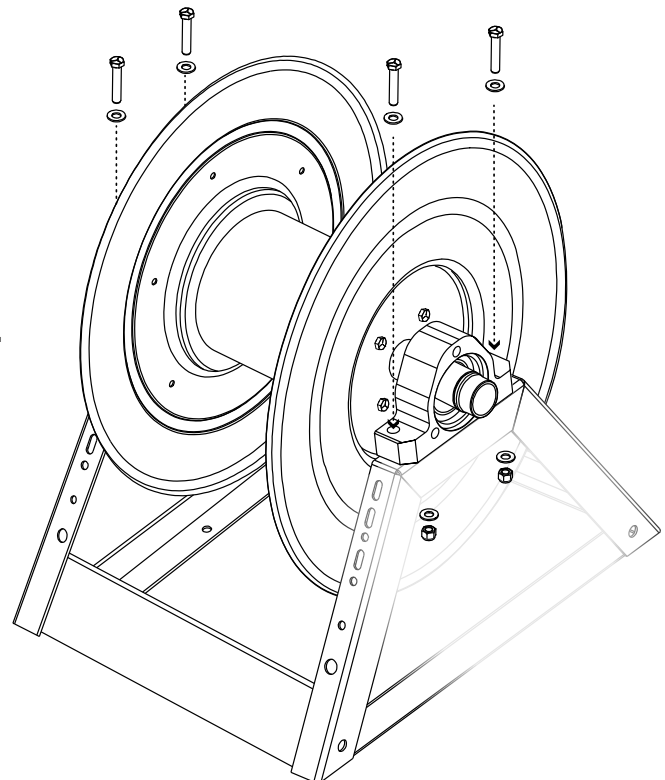

Step 5

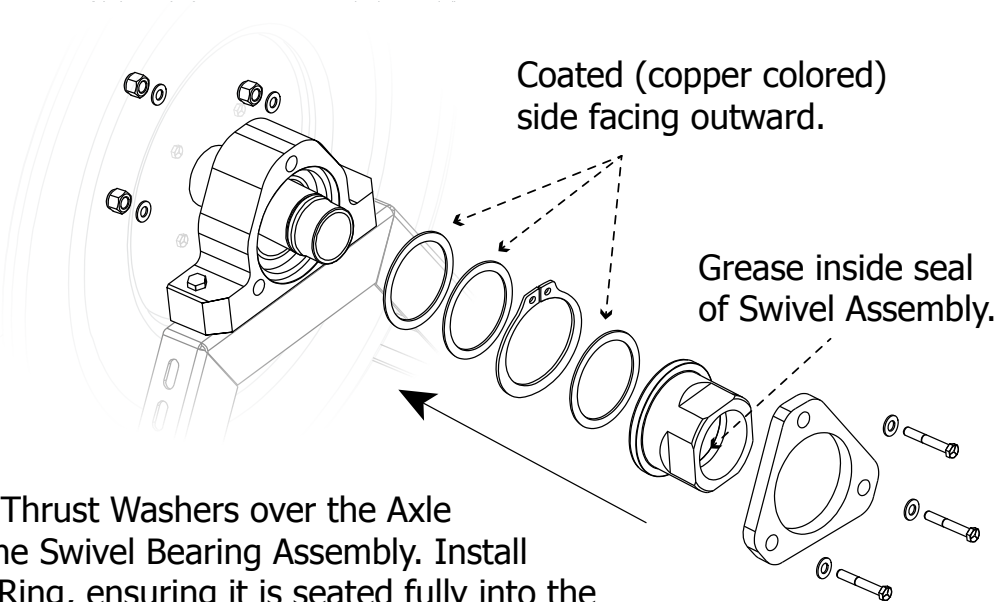

Place two Thrust Washers over the Axle and into the Swivel Bearing Assembly. Install Retaining Ring, ensuring it is seated fully into the Axle groove. Place a third Thrust Washer after the Retaining Ring. Slide the Swivel Assembly over the Axle until it sits flush with the Swivel Bearing Assembly. Install the Outer Swivel Plate using three 3/8-16 x 2-1/2" bolts, six 3/8" washers and three 3/8" nuts.

Step 6

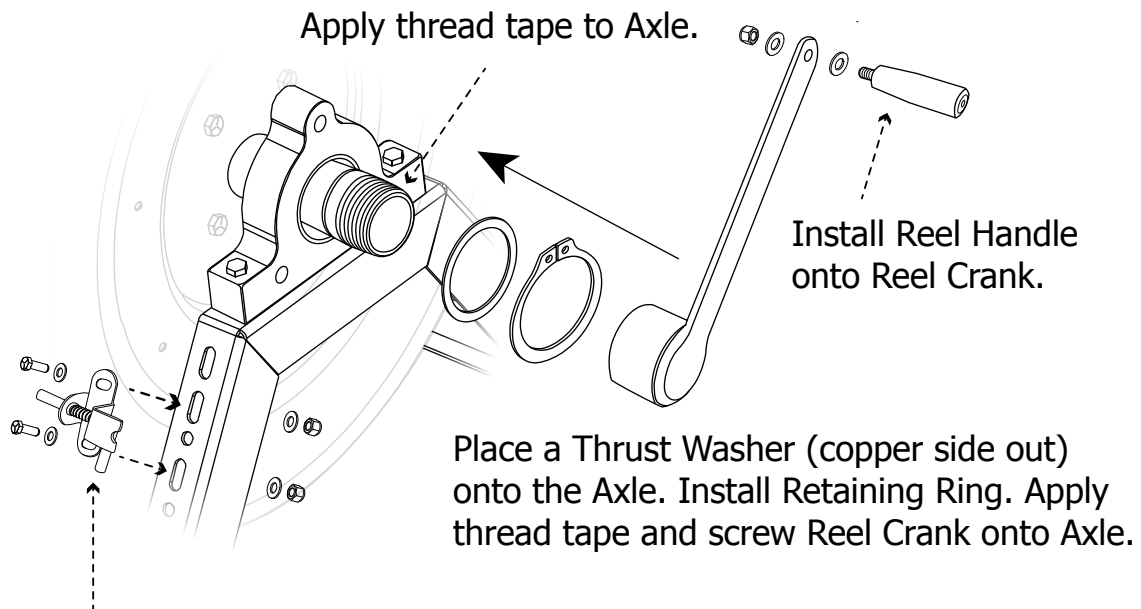

Place a Thrust Washer (copper side out) onto the Axle. Install Retaining Ring. Apply thread tape and screw Reel Crank onto Axle.

Install Reel Lock onto Frame using two 5/16-18 x 7/8" bolts, four 5/16" washers and two 5/16" nuts. Line up the Reel Lock pin with the Locking Hose Guide holes. Crank the reel a full turn to ensure it does not rub on the Hose Guide. Adjust if needed, then tighten bolts on the Reel Lock and Assemblies.

